

Layout & Design Guidelines for Boat Launching Facilities



CALIFORNIA DEPARTMENT
OF PARKS AND RECREATION
DIVISION OF
BOATING AND WATERWAYS



2021

Preface

The **2021 Layout & Design Guidelines for Boat Launching Facilities (2021 Guidelines)** presents a broad range of information regarding the layout, design and construction of boat launching facilities, including the **2010 ADA Standards for Accessible Design**. The **2021 Guidelines** will be of benefit to engineers, architects, contractors, material suppliers, manufacturers, administrators, boating facility owners and operators, maintenance personnel and the recreational boating community statewide.

The development of guidelines for boat launching facilities began in the 1960s. The first edition was created in 1968 by the **Department of Harbors and Watercraft**. The department became the **Department of Navigation and Ocean Development** in 1969, and the **Department of Boating and Waterways (DBW)** ten years later in 1979. A number of subsequent guidelines were published over the ongoing years up to the present.

On July 1, 2013, **DBW** was merged into the **California Department of Parks and Recreation** under which future guidelines such as the **2021 Guidelines** will be updated and improved. The **2021 Guidelines** are comprehensive in the range of topics addressed including commentary that explains some of the more difficult issues. This document has been completed under the oversight of the **State Parks Divisions of Boating and Waterways, and Acquisition and Development**.

We wish to extend a word of thanks to those persons, agencies and organizations who participated in the process of guidelines development over the years, and to the various people who reviewed and commented on the final review draft of the **2021 Guidelines**.

The **2021 Guidelines** were developed under the direction and supervision of Mr. Steve Watanabe, P.E., Supervising Civil Engineer, Department of Parks and Recreation, Acquisition and Development Division and Karl Rose, P.E., Senior Civil Engineer, California State Parks, Facilities & Development Division. The author and editor is Bill Curry, P.E. (RA).

Ramona Fernandez



Acting Deputy Director
Division of Boating and Waterways

Brian Dewey



Assistant Deputy Director
Facilities and Development

Special Acknowledgment

This latest edition of the Division of Boating and Waterways' *Layout & Design Guidelines for Boat Launching Facilities* is dedicated to Bill Curry who peacefully passed away on June 6, 2020 at the age of 81. A native of Amarillo, Texas, Bill was recruited out of Texas Tech University in 1963 to work on California's monumental State Water Project. When the project was completed in 1968, Bill moved on to the Department of Harbors and Watercraft (precursor to the Division of Boating and Waterways) where he began a very remarkable career ultimately retiring in 2002 as the Chief Engineer. Bill continued to work as a retired annuitant with DBW for many years providing significant contributions to the recreational boating community.

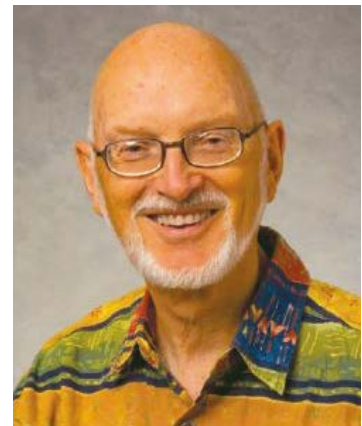

Bill Curry

Recognizing the need to provide technical assistance to DBW grantees on how to properly design and construct boat launching facilities, Bill authored the first ever *Layout, Design and Construction Handbook for Small Craft Boat Launching Facilities* in the early 1970s. The handbook essentially codified boat launching facility design and construction in California and was extremely well-received by DBW grantees. Bill had a tremendous talent for being able to make a technical document understandable and relatable to all audiences, whether they be engineers, contractors, building officials, boat ramp operators, regulators or the general public, which is why his handbook had such universal appeal.

Besides authoring DBW's boat launching facilities handbook, Bill also authored DBW's *Marina Berthing Facilities – Design Guidelines and DBW's 2010 ADA Standards Excerpts for Recreational Boating Facilities*, which explained how to design boat launching facilities and marinas in compliance with the Americans with Disabilities Act. A gifted engineer, Bill also designed California's first floating restroom for boaters, which eventually led to the development of DBW's highly successful floating restroom program.

Bill's contributions to the recreational boating community both in California and nationally have been extensive and long-lasting. Bill also served as a commissioner on California's Delta Protection Commission, was the 2002 recipient of the States Organization for Boating Access' prestigious William H. Ivers Award, and was a tireless advocate for making boating facilities accessible for persons with disabilities.

Bill will be remembered as a warm and compassionate human with an extraordinary gift for making people smile with his puns; whether as a friend, colleague, mentor or source of inspiration you were lucky to have known him. Fair winds and following seas, Mr. Curry.

Contents

- Introduction** **9**

- Section A: Definitions** **11**

- Section B: Water Areas** **14**

- B1. Fairways 14
 - B1.1 Minimum Fairway Depth 14
 - B1.2 Minimum Fairway Bottom Width 14
 - B1.3 Minimum Fairway Length 14

- B2. Channels 14
 - B2.1 Minimum Channel Depth 14
 - B2.2 Minimum Channel Bottom Width 14
 - B2.3 Channel Markers 14

- B3. Signs and Waterway Markers 15
 - B3.1 Swimming Areas Adjacent To Launching Ramps 15
 - B3.2 Waterway Markers 15

- Section C: Launching Ramps** **16**

- C1. General Requirements 16
 - C1.1 Launching Ramp 16
 - C1.2 Minimum Widths of Launching Lanes 16
 - C1.3 Number of Launching Lanes 17
 - C1.4 Arrangement of Launching Lanes 17
 - C1.5 Design High and Design Low Water Elevations 18
 - C1.6 Length of Launching Ramps 19
 - C1.7 Launching Ramp Slopes 19
 - C1.8 Launching Ramp Vertical Curves 20
 - C1.9 Launch Ramp Aprons, Approach, Turning Patterns, and Turn-Around Area 20
 - C1.10 Turn-Around Areas on Launching Ramps 22

- C2. Construction Details, Materials and Procedures 23
 - C2.1 Cast-in-Place Concrete Launching Ramps 23
 - C2.2 Precast Concrete Panels 24
 - C2.3 Cellular Concrete Mats 26
 - C2.4 Concrete Push Slabs 27

| | | |
|-----------------------------------|--|-----------|
| C2.5 | Concrete Mix Specifications for Launching Ramps | 28 |
| C2.6 | V-Groove Launching Ramp Finish Details | 28 |
| C2.7 | V-Groove Tool Design and Fabrication | 30 |
| C2.8 | V-Groove Launching Ramp Construction Procedure | 30 |
| C2.9 | Construction Joints | 31 |
| C2.10 | Weep Holes | 31 |
| C2.11 | Erosion Control Features | 32 |
| Section D: Boarding Floats | | 33 |
| D1. | General Requirements | 33 |
| D1.1 | Width Requirements | 33 |
| D1.2 | Length Requirements | 35 |
| D1.3 | Height Requirements | 35 |
| D2. | Loading Design Criteria | 36 |
| D2.1 | Dead Load Only (DLO) | 36 |
| D2.2 | Uniform Live Loads (ULL) | 36 |
| D2.3 | Live Point Loads (LPL): | 37 |
| D2.4 | Freeboard | 38 |
| D2.5 | Wind, Wave, Current and Impact Loadings | 38 |
| D2.6 | Deflections | 39 |
| D2.7 | Gangplank and Gangway Loadings | 40 |
| D3. | Design Details | 40 |
| D3.1 | Hardware | 40 |
| D3.2 | Decking | 42 |
| D3.3 | Pontoons | 43 |
| D3.4 | Fender Boards | 44 |
| D4. | Types of Boarding Float Systems | 45 |
| D4.1 | Non-Floating Boarding Platforms | 45 |
| D4.2 | Suspended Non-Floating Boarding Platforms | 45 |
| D4.3 | Pile-Guided Articulated Boarding Floats/Fixed Abutment | 46 |
| D4.4 | Cable-Guided Boarding Floats | 47 |
| D4.5 | Single-Rail Guided Boarding Floats | 48 |
| D4.6 | Dual-Rail Guided Boarding Floats | 49 |
| D5. | Abutments | 52 |
| D5.1 | General Requirements | 52 |
| D5.2 | Design Details | 53 |
| D6. | Guide Piles | 54 |
| D6.1 | General Requirements | 54 |
| D6.2 | Design Details | 55 |

| | | |
|--|--|-----------|
| D7. | Pile Yokes | 56 |
| | D7.1 General Requirements | 56 |
| | D7.2 Exterior Pile Yokes | 57 |
| | D7.3 Interior Pile Yokes | 58 |
| | D7.4 Pile Yoke Rollers and Rub Strips | 60 |
| | D7.5 Pile Yoke Design Details | 61 |
| | D7.6 Pile Yoke and Boarding Float Rotation | 63 |
| D8. | Gangplanks | 66 |
| | D8.1 General Requirements | 66 |
| | D8.2 Accessible Gangplanks | 66 |
| | D8.3 Design Details | 69 |
| D9. | Gangways | 70 |
| | D9.1 General Requirements For Application At Boat Launching Ramps | 70 |
| | D9.2 Gangway Minimum Uniform Live Loads (ULL) | 72 |
| | D9.3 Gangway Minimum Width | 72 |
| | D9.4 Gangway Railings | 72 |
| | D9.5 Gangway Decking | 73 |
| | D9.6 Maximum Gangway Slopes | 74 |
| | D9.7 Gangplanks Provided at the Lower and/or Upper Ends of a Gangway | 74 |
| | D9.8 Transition Plates | 74 |
| | D9.9 Boarding Floats and Gangway Landings | 75 |
| | D9.10 Accessible Gangways | 75 |
| Section E: Shoreside Facilities | | 77 |
| E1. | Parking Facilities | 77 |
| | E1.1 Types of Boat Launching Facilities Parking Spaces | 77 |
| | E1.2 Location of Parking Spaces | 79 |
| | E1.3 Minimum Number of Parking Spaces | 79 |
| | E1.4 Minimum Parking Space Dimensions | 79 |
| | E1.5 Parking Lot Finish Grades | 81 |
| E2. | Accessible Parking Spaces (Barrier-Free Parking) | 81 |
| | E2.1 General Requirements | 81 |
| | E2.2 Minimum Number of Accessible Parking Spaces | 82 |
| | E2.3 Minimum Dimensions and Layout Factors | 83 |
| | E2.4 Access Aisles | 85 |
| | E2.5 Parking Space Signs and Pavement Markings | 88 |

| | | |
|------|---|------------|
| E3. | Roadways and Parking Areas | 91 |
| E3.1 | Access Roads | 91 |
| E3.2 | Parking Lot Driveways | 92 |
| E3.3 | Parking Lot Pavement Design Considerations | 93 |
| E3.4 | Unpaved Parking | 94 |
| E4. | Restroom Facilities | 94 |
| E4.1 | General Requirements | 94 |
| E4.2 | Public Health and Accessibility Requirements | 95 |
| E5. | Utilities | 96 |
| E5.1 | Potable Water | 96 |
| E5.2 | Oil Recovery and Sewer Systems | 96 |
| E5.3 | Area Lighting | 96 |
| E5.4 | Overhead Electrical Powerlines | 97 |
| E6. | Signs | 98 |
| E6.1 | Types of Signs | 98 |
| E6.2 | Location, Orientation and Legibility | 100 |
| E6.3 | Size of Signs | 100 |
| E6.4 | Design Details | 101 |
| | Appendix A: Commentary | 102 |
| | Appendix A: Commentary – Section C | 103 |
| | Appendix A: Commentary – Section D | 130 |
| | Appendix A: Commentary – Section E | 148 |
| | Appendix B: 2010 ADA Standards – Recreational Boating Facilities | 162 |
| | Appendix C: 2019 California Building Code | 163 |

Introduction

The primary purpose of the **2021 Layout & Design GUIDELINES for Boat Launching Facilities** is to provide technical assistance and direction for planning, design and construction. Recreational boat launching facilities are funded under Local Assistance and Capital Outlay programs administered by the California Department of Parks and Recreation Division of Boating and Waterways (DBW), and Acquisition and Development, Boating Facilities Unit.

The **GUIDELINES** address typical conditions and are not intended to be all inclusive or absolute. Unique site conditions and circumstances may require special analysis, applications and design considerations not addressed herein. Special care and attention should always be applied to each project to ensure excellent design, the most appropriate selection of materials, and a boat launching facility that is safe, functional, attractive, durable and sustainable over the design life of the project.

The information in these **GUIDELINES** is useful for recreational boating facility issues in general, and will be helpful to anyone involved in the development of both new and altered boating facilities.

These **GUIDELINES** do not address site selection considerations for new boat launching facilities, or site considerations for expansion of existing facilities. Also, environmental practices, fish cleaning stations, boat engine oil recycling facilities, collection of solid waste materials, and permitting issues are beyond the scope of this document.

In the presentation of design and construction criteria, the following convention is used:

§ Criteria printed in “standard type” are recommended general criteria; and

§ Criteria printed in “***bold italics type***” are minimum safety criteria.

It is recognized that in certain isolated instances the application of minimum safety criteria may not be feasible, desirable or even possible. A better alternative may very well exist at a given site that will not jeopardize safety and is judged to be equal to or better than the minimum criteria presented herein. Deviations from the minimum criteria will be considered on a case-by-case basis jointly by the project owner, DBW Grants and Loans Unit Manager, Boating Facilities Unit, and the permitting agency(s) issuing the building permit(s). Individual project owner/operators will bear the responsibility to clearly document the rationale for any deviation(s).

It is not intended that deviations from either the recommended general criteria or the minimum safety criteria be used to justify wholesale departures from the advice, direction, experience and criteria presented herein. To varying degrees, these **GUIDELINES** represent the collective experience, wisdom and advice of boaters, harbor masters, material suppliers, designers, engineers, architects, consultants, contractors, government officials, and various other persons and groups representing both public and private interests compiled over a period of five decades from the late 1960s to the present. The intent is that these updated **GUIDELINES** will be a reliable guide for the planning, layout, design and construction of boat launching facilities.

These **GUIDELINES** may be viewed and/or downloaded from the web site indicated below. It is requested that the **GUIDELINES** be used as a complete document, and not be edited, altered or changed in any way from its officially published form.

DBW Publications:

http://dbw.parks.ca.gov/?page_id=28827

Should you wish to submit comments, corrections and/or suggestions to be considered for future editions of these **GUIDELINES**, contact Karl Rose P.E. as indicated below.

California State Parks
Facilities & Development Division
One Capitol Mall, Suite 410
Sacramento, CA 95814
(916) 812-0358
info@parks.ca.gov

COMMENTARY FLAGS

The “Flag” symbol seen in the right margin beside this paragraph will be seen beside various sections and sub-sections throughout Sections C, D and E of these **GUIDELINES**. A notification “flag” indicates that commentary is provided in Appendix A on the particular section, subject and topic flagged.



The individual Appendix A commentary headings refer back to specific sections and sub-sections flagged in Sections C, D and E, providing a two-way reference system.

Section A: Definitions

Color Key to Defined Terms:

Definitions in:

| | |
|---|---|
| ALL CAPS BOLD BLACK PRINT | are stand-alone definitions |
| ALL CAPS BOLD ITALICIZED RED PRINT | are headings for sub-sets of related definitions; and |
| <u>lower case bold indented underlined blue print</u> | are sub-set definitions under a heading. |

ABUTMENT a fixed wedge-shaped structure at the head of a launching ramp to which stationary boarding floats are hinged, and which provides pedestrian access between shore and the boarding floats

BOARDING FLOAT a platform-type structure, either floating or fixed, stationary or adjustable, located immediately alongside of or on a launching ramp, designed for short term moorage of boats and facilitation of pedestrian access to and from boats in the water

DOCK a platform, either floating or fixed, provided at a boat launching facility for the temporary securing of a boat to facilitate pedestrian access to and from the boat [synonymous with **BOARDING FLOAT**]

CHANNEL a waterway, natural or artificially dredged, that is delineated, operated and maintained for the safe passage of boats between a boat launching ramp and the main waterbody upon which the primary boating activities occur

entrance channel a watercourse, external to a boat launching facility basin, marina basin, etc., through which boats travel between the facility and the water body where the primary boating activities occur

interior channel a watercourse, within a boat launching facility basin, marina basin, etc., through which boats travel between the facility and an entrance channel

COURTESY DOCK a dock (not on a launching ramp) that is accessible via a gangway, which together typically form an “L” or “T” shape configuration

| | |
|--------------------------|---|
| DESIGN HIGH WATER | a selected high water level based on hydrologic data and other appropriate records, which is used as a safe and practical upper limit for the design and construction of a launching ramp |
| DESIGN LOW WATER | a selected low water level based on hydrologic data and other appropriate records, which is used as a safe and practical lower limit for the design and construction of a launching ramp |
| FACILITY | all or any portion of buildings, structures, site improvements, elements, pedestrian routes and vehicular ways located on a boat launching site |
| FAIRWAY | bay, lagoon, basin, watercourse or other waterway into which a launching ramp extends for the launching and retrieval of boats |
| FREEBOARD | vertical height from the water surface to the top of the deck of a boarding float or dock, measured under various loading conditions [dead load only, live+dead load...) |
| GANGPLANK | a 5% maximum slope platform or bridge, without guard rails and handrails, that provides pedestrian access between the sloped surface of a boat launching ramp and a boarding float that is not attached to an abutment (i.e., a cable guided or rail guided boarding float, or a pile guided boarding float designed to ride high on piles in flood waters) |
| GANGWAY | a variable-sloped pedestrian walkway that links a fixed structure or land with a boarding float (gangways that connect to vessels are not included in this definition) |
| GUIDE PILE | a vertical pile within a pile yoke that holds the boarding float on location, and allows it to rise and fall with changing water levels |
| HIGH WATER | the extreme high water level projected to occur at a launching ramp site |
| LOW WATER | the extreme low water level projected to occur at a launching ramp site |
| LAUNCHING RAMP | an inclined surface consisting of one or more launching lanes extending down into a fairway, and upon which trailered and other watercraft are launched into and retrieved from a waterbody |
| <u>apron</u> | a dedicated maneuvering area serving as a transition between parking area driveways and a launching ramp |

| | |
|-------------------------|---|
| <u>head of ramp</u> | the upper end of a launching ramp |
| <u>launching lane</u> | a clearly delineated longitudinal section of a launching ramp, designed to accommodate the launching or retrieval of one boat at a time |
| <u>slope of ramp</u> | the percent slope of a launching ramp determined by dividing the vertical drop by the horizontal projection, and multiplied by 100 [a 15% ramp drops 15 ft vertically each 100 ft horizontally] |
| <u>toe of ramp</u> | the lower end of a launching ramp |
| <u>turn-around area</u> | an area of expanded overall width of a long launching ramp to facilitate turning vehicles and trailers around in preparation for launching and/or retrieving boats, and to minimize the backing distance when launching a boat at low water |
| PILE YOKE | a frame, ring or other structural device attached along the side of a boarding float, or a framed opening in a boarding float, through which a guide pile passes and keeps the boarding float in a specific location |
| TOE PLATE | a sloping pedestrian walkway surface that provides a smooth and even transition between the sloping surface of a boat launching ramp and a gangplank |
| TRANSITION PLATE | a sloping pedestrian walkway plate that provides a smooth and even transition between a gangway and shore, and/or between a gangway and a floating dock |
| V-GROOVE | the saw-tooth pattern usually imparted diagonally across the surface of a concrete boat launching ramp to provide traction for vehicles launching and retrieving trailered boats |
| VERTICAL CURVE | a circular crest curve in the vertical profile at the upper end of a launching ramp that provides a smooth transition between the relatively level slope of the apron and the fixed slope of the launching lanes |

Section B: Water Areas

B1. FAIRWAYS

B1.1 Minimum Fairway Depth

4 ft below design low water (DLW) (includes depth for buildup of siltation; see Section C1.6.3 on page 19)

B1.2 Minimum Fairway Bottom Width

Not less than the combined width of the launching ramp and riprap shoulders or other shore protection provided immediately adjacent to the sides of the launching ramp.

B1.3 Minimum Fairway Length

B1.3.1 50 ft beyond toe of ramp at design low water (DLW).

B1.3.2 ***Fairway shall be clear of navigational hazards and obstructions.***



launching ramp fairway

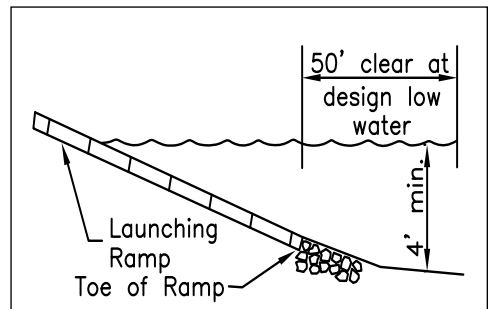

minimum fairway length and depth

B2. CHANNELS

B2.1 Minimum Channel Depth

4 ft at design low water (DLW)

B2.2 Minimum Channel Bottom Width

75 ft

B2.3 Channel Markers

In cases where channels are constructed through lowlands or tidal areas which are periodically submerged, such channels should be marked with appropriate

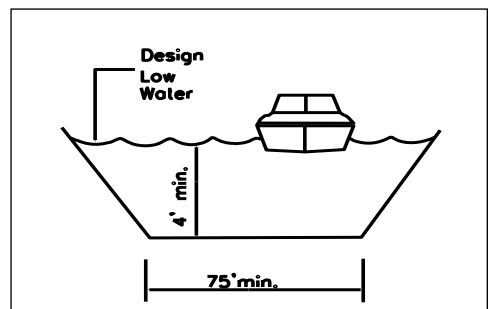

minimum channel depth and bottom width

navigational aids such as buoys, piles, lights or other devices in accordance with the California Waterway Marker System.

B3. SIGNS AND WATERWAY MARKERS

B3.1 Swimming Areas Adjacent To Launching Ramps

B3.1.1 *Adjacent swimming areas and boat launching facilities shall be clearly delineated and separated by:*

- signs;
- barrier fences;
- walls;
- piers;
- breakwaters;
- log booms;
- buoys and buoy lines;
- piles;
- lights; and/or
- other appropriate devices.



no swimming sign at end of float

B3.1.2 *Such barriers and warning devices shall extend out into the water a distance not less than the recognized extent of the swimming area(s) under all water level conditions when boat launching and swimming occur.*

B3.2 Waterway Markers

Where adjacent boat launching facilities and swimming areas exist, both activity areas shall be identified by highly visible weather resistant signs and waterway markers installed on both the shore and on floating barriers. Warning devices must be provided where necessary. Signs and waterway markers shall be in accordance with the California Waterway Marker System.

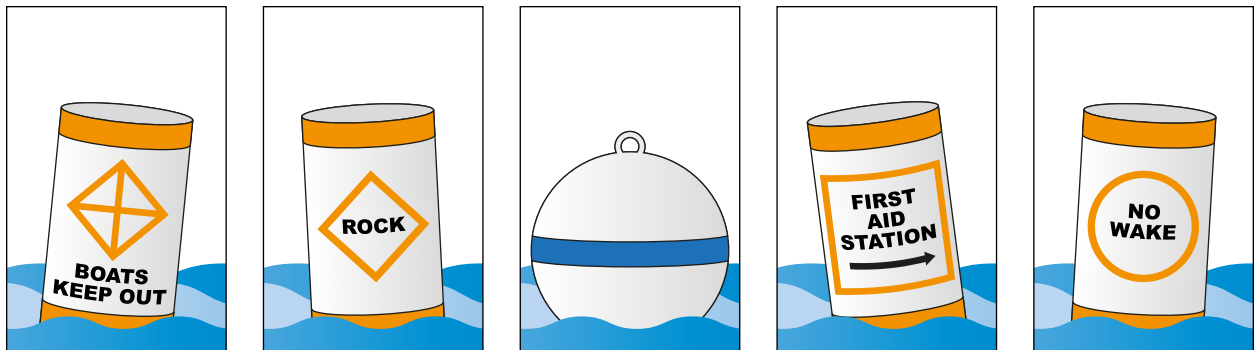

examples of waterway marker buoys and signs

Section C: Launching Ramps

C1. GENERAL REQUIREMENTS

C1.1 Launching Ramp

A launching ramp typically consists of one or more concrete launching lanes and boarding floats. The overall width of a launching ramp includes the launching lanes and the concrete slab under the boarding floats for support of the floats when they come to rest at low water.

C1.2 Minimum Widths of Launching Lanes

C1.2.1 Multiple-Lane Launching Ramps

C1.2.1.1 *Minimum launching lane width shall be not less than 15 ft.*

C1.2.1.2 The minimum launching lane width includes the width of 3-inch wide “shiny edge” troweled finishes along the edges of launching lanes, but not the width of raised curbs. A full minimum 15-ft launching lane width must be provided for maneuvering vehicles and trailers while launching and retrieving boats.

C1.2.1.3 Delineate each launching lane with a standard 3-inch wide shiny edge finish along the following edges:

- across the top edge (head of ramp);
- down both longitudinal edges; and
- across bottom and top edges of planned transverse construction joints

C1.2.2 Single-Lane Launching Ramps

C1.2.2.1 *Single-lane launching ramps up to 50 ft in length shall have a minimum width of not less than 16 ft.*



multiple launching lanes



3-inch shiny edge finish

C1.2.2.2 Single-lane launching ramps over 50 ft in length are recommended to be 20 ft wide.

C1.3 Number of Launching Lanes

C1.3.1 One launching lane will generally handle up to 50 boat launchings and 50 boat retrievals per day at a well designed and operated facility.

C1.3.2 The number of launching lanes at a given site will be determined by user demand and the characteristics of the site. This will vary between urban and rural locations, the primary type(s) of boating that occurs on a specific waterbody, vehicle parking capacity, the seasonal drawdown of the waterbody and the length of the launching ramp.

C1.4 Arrangement of Launching Lanes

C1.4.1 Factors that influence launching lane arrangements include:

- number of launching lanes;
- presence of boarding floats between launching lanes;
- length of the launching ramp; and
- alignment of the launching ramp relative to entrance and exit driveways.

C1.4.2 On multiple launching lane ramps, the lanes should be arranged in pairs. A two-lane launching ramp with boarding floats located along both outside edges is the most common basic boat launching facility. Larger launching facilities should consist of even numbered pairs of launching lanes, i.e., 4-lanes, 6-lanes, etc.

C1.4.3 Launching ramps with three adjacent launching lanes should usually be avoided. Boats launched in the center lane would not have direct access to a boarding float. However, for operational, safety and boat traffic reasons, a boat launching facility (in a large marina) that has three adjacent launching lanes provides a wide emergency access for fire boats, fire trucks and equipment in the event of a burning boat and/or dock.



single-lane launching ramp



two (2) pairs of launching lanes



8 lane launching ramp with 2 pairs of three adjacent boat launching lanes bordered by 2 single lanes



C1.4.4 An unusual arrangement is a two-lane launching ramp with one lane designated for use by powerboats, and the other lane for non-motorized boats such as kayaks, canoes and inflatables. The powerboat launching lane should be finished with typical 1 inch V-grooves to provide adequate traction for vehicles launching and retrieving powerboats. However, 1/2 inch V-grooves should be used on the surface of the non-motorized boat launching lane. The smaller grooves are more “bare-foot-boater friendly” for the users, and vehicle traction is not a problem for launching and retrieving non-motorized boats.



rowing shell being hand-launched



two-lane launching ramp 1 inch V-grooves on right lane 1/2 inch V-grooves on left lane

C1.5 Design High and Design Low Water Elevations



C1.5.1 It is recommended that at least 25 years of reliable water level data be used to establish design high and design low water for new launching ramps. If reliable water level data is not available, confer with local city and county officials, water agencies, districts, law enforcement officers, search and rescue organizations, newspapers and television/radio stations. Input from nearby land owners and long-term residents can also be of great value by providing their experiences, observations and photos that have day, month and year notations.

C1.5.2 Boat launching facilities located on waterways subject to future sea level rise (SLR) must be planned to anticipate increased design high water levels. Documents are being developed under the direction of the California Ocean Protection Council (OPC) for guidance to incorporate SLR projections into planning and construction of future shoreline projects, including boat launching facilities. The science of future SLR is evolving. The amount and rate of future SLR will be subject to periodic adjustments for many years to come. For current SLR projections and information on this matter, go to: www.opc.ca.gov. BLF projects funded by DBW must be designed for a minimum of 20 years of SLR after construction is completed.

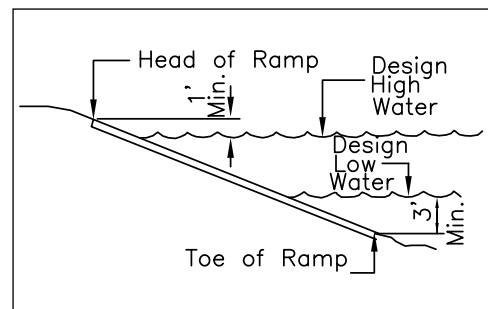

minimum toe of ramp water depth

C1.6 Length of Launching Ramps

C1.6.1 The actual length of a launching ramp is determined by the following:

- design high and design low water elevations;
- launching ramp head and toe elevations;
- launching ramp design slope; and
- site topography.

C1.6.2 The head-of-ramp elevation should be a minimum of 1 ft above design high water.

C1.6.3 The toe-of-ramp elevation should be minimum of 3 ft below design low water.

C1.7 Launching Ramp Slopes

A launching ramp is usually a uniform slope beginning where it joins to the lower end of a vertical curve immediately above the ramp slope, and ends down slope at the toe of the ramp.

C1.7.1 Range of Launching Ramp Slopes

| | |
|---------------------|---------------------|
| Max. Slope: 15% | Min. Slope: 12% |
| 15 ft V to 100 ft H | 12 ft V to 100 ft H |
| 1:6.67 | 1:8.33 |

C1.7.2 The slope of a launching ramp should be uniform throughout its length. If necessary to alter the slope at some point down the ramp, the slope change should be from a flatter slope to a steeper slope. Going the other way from a steeper slope to a flatter slope forms a shallow valley on the launching ramp that may cause the skieg on an outboard engine locked in the down position to strike the ramp surface when launching and retrieving a boat. It may also cause tensioned cables on cable-guided float systems to be suspended above the launching ramp surface. In either case, the change in slope should be made with a long vertical curve to provide a safe and comfortable transition between the two slopes. The greater the change, the greater the potential problems.

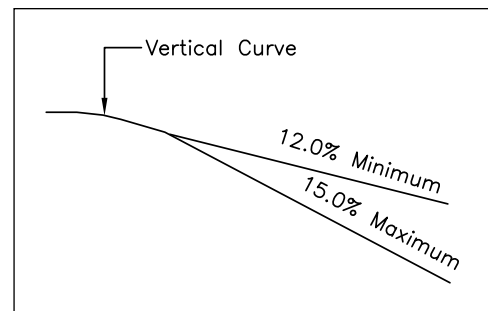

range of launching ramp slopes



vertical curve at head-of-ramp

C1.8 Launching Ramp Vertical Curves

C1.8.1 Provide a 20 to 25 ft vertical curve in the launching ramp apron to provide a smooth and safe vehicle-trailer transition between parking area driveways and the 12% to 15% launching ramp slope. This provides a uniform slope throughout the ramp length, and eliminates potential problems with the functioning of boarding floats, gangplanks and boarding float guidance systems. If DHW is within the vertical curve, provide v-groove starting at 1 ft higher than DHW.



launching ramp apron merging with vertical curve

C1.8.2 At salt water coastal locations, full width launching ramp aprons 60 to 80 ft long should be of reinforced concrete construction rather than paved with asphalt concrete (AC). Under continuous exposure to vehicle and trailer wheel loads, and salt water dripping from boats and trailers just removed from the water, AC paving has not proved to be as durable as concrete.

C1.9 Launch Ramp Aprons, Approach, Turning Patterns, and Turn-Around Area

C1.9.1 A launching ramp apron must be provided at the head of a launching ramp. The apron functions as a transition area between the driveways, the parking areas, and the launching ramp. It also serves as a maneuvering area where boaters can position their vehicles and trailers to line up with particular launching lanes in preparation for launching and retrieving their boats.

C1.9.2 All other factors being equal, the initial approach to the launching ramp should be in a counter-clockwise pattern. This rotation will: (1) keep the trailer in full view in the driver's sideview mirror; (2) greatly assist in achieving alignment with a launching lane; (3) enhance safety for vehicles, drivers and pedestrians; and (4) be helpful to drivers who are not proficient at backing boat trailers.

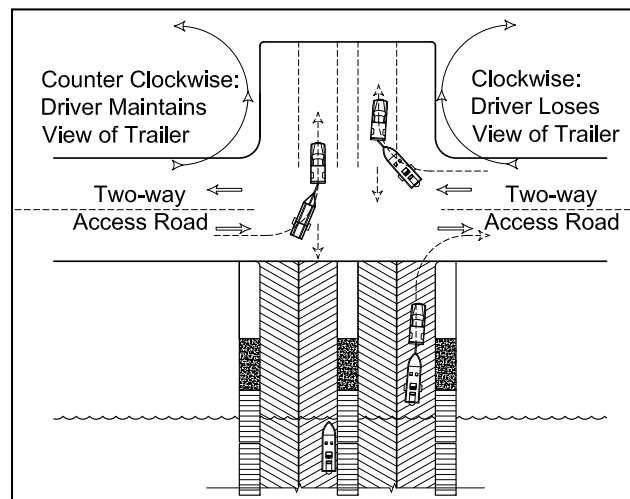

benefits of counter-clockwise turning

C1.9.2.1 To impose a clockwise turning pattern dictates that during the initial approach to the launching

ramp, the trailer will be out of the driver’s sideview mirror for much of the maneuvering operation. However, on large multi-lane launching ramps of six to ten adjacent launching lanes uninterrupted by boarding floats, and with vehicle access from two or more directions, this may be a moot point. Such expansive launching ramp areas provide maximum flexibility in using the facilities, but on busy boating days during the summer boating season it can also lead to chaos and lack of organized traffic flow.

C1.9.2.2 At smaller launching facilities with four or less launching lanes, a counter-clockwise traffic pattern should be utilized unless local conditions, land configuration and/or the location and alignment of existing entrance roads dictates otherwise.

C1.9.3 The size and configuration of a turn-around area will be dictated by the layout of the launching ramp relative to entrance and exit access roads, the location of vehicle-trailer parking areas, and the direction from which vehicles pulling trailers will approach the launching ramp.

C1.9.4 A minimum 60 ft diameter turn-around area immediately above a launching ramp apron is recommended. Most automobiles, pickup trucks, SUVs and RVs pulling recreational boat trailers will be able to negotiate 360 degree turns within a 60 ft diameter circle.

C1.9.5 In cases where access roadways to a launching ramp are parallel to and near the shoreline, it may be difficult to provide both a turn-around area and ramp apron between the roadway and the head of the launching ramp. In such cases, a “cross” shaped layout can work, providing for thru-traffic flow, a turning area, and accommodation for both clockwise and counter-clockwise traffic patterns. For example, counter-clockwise vehicle-trailer traffic would approach the top left side of the

launching ramp, turn 90 degrees counter-clockwise to the left away from the shoreline, line up with a launching lane, back up across the access roadway and ramp apron, and proceed down the launching ramp. The entrance and exit roadways form the arms of the “cross” providing entrance from one side of the launching ramp and exit out the other side. The “vertical leg” of the “cross” must be long enough to provide:

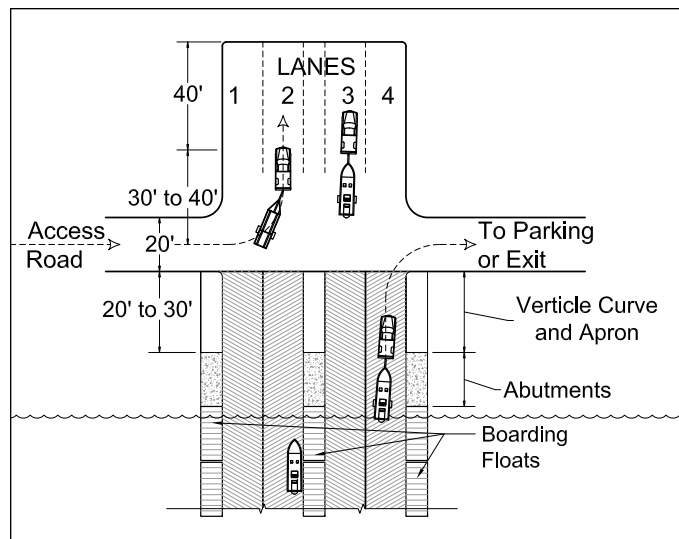

“cross” shaped turn-around area

- for 90 degree turns away from the shoreline (30-40 ft);
- the length of a vehicle and trailer for alignment with a launching lane (up to 65 ft for an RV with trailer);
- the width of the thru-traffic access roadway; and
- the length of the apron down to the head of the launching ramp. Measured from the head of ramp, the length of the “vertical leg” of the cross can be up to 150 ft.

C1.9.6 The launching ramp apron should be constructed of the same reinforced concrete as used for launching ramps. Aprons are sometimes used as boat-ready areas during launching and retrieval of boats. The apron will be continuously wet during busy use periods, and subjected to erosive dripping of water and debris from wet trailers and boats. AC paved aprons have not proven to be durable under these conditions, particularly on coastal saltwater launching ramp aprons. They erode and break down rather rapidly requiring repair, resurfacing and/or replacement more frequently than more durable concrete aprons.

C1.10 Turn-Around Areas on Launching Ramps

C1.10.1 A turn-around area is an expansion in the clear overall width of a long launching ramp to facilitate turning vehicles and trailers around in preparation for launching and/or retrieving boats. The primary purpose of a turn-around area is to minimize vehicle/trailer backing distances during low water periods.

C1.10.2 ***Where possible to do so, a turn-around area shall be provided at 200 ft maximum intervals, be a minimum of 60 ft in diameter, and be finished with the same V-groove ramp finish as the launching lanes.***

C1.10.2.1 Launching ramps with at least four (4) adjacent launching lanes totaling a minimum clear width of not less than 60 ft do not require designated turn-around areas. Such launching ramps are wide enough for most vehicles pulling boat trailers to turn around at any point along the length of the launching ramp.

C1.10.2.2 A turn-around area should not interrupt the clear delineation of launching lanes above, through and below the turn-around area.

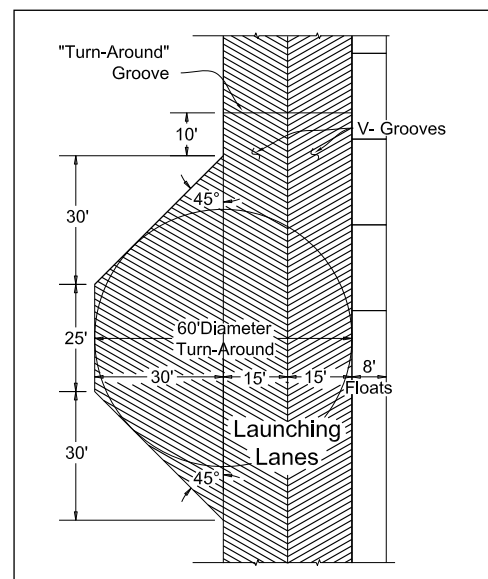

turn-around area dimensions

C2. CONSTRUCTION DETAILS, MATERIALS AND PROCEDURES

C2.1 Cast-in-Place Concrete Launching Ramps

Cast-in-place launching ramps constructed with reinforced concrete is the primary method of launching ramp construction because of the monolithic nature of the completed launching ramp, its strength and durability, and relative ease of construction. It is the method that should be used unless local conditions dictate the use of precast panels or push slabs.

C2.1.1 Cast-in-place concrete slabs can be constructed “in-the-dry” or by “de-watering” in both fresh and salt water. De-watering may occur naturally in lakes and reservoirs subject to seasonal water level drawdowns. De-watering of river and coastal sites can be accomplished through the use of cofferdams.

C2.1.1.1 The same minimum launching ramp slab thickness and rebar cover dimensions should be used in both fresh and salt water environments in consideration of possible settlement, cracking, inaccurate placement of steel reinforcement, poor inspection, and an expected 20-year launching ramp service life.

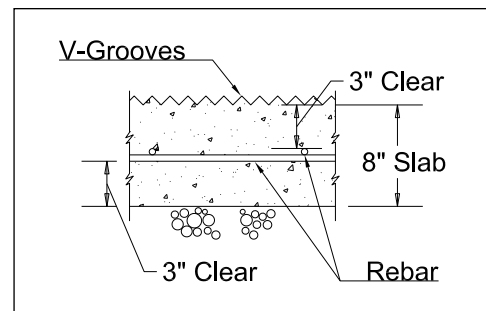

minimum slab thickness

- Minimum slab thickness: 8 inches
 - > measured from bottom of V-grooves to bottom of slab
- Minimum concrete cover: 3 inches
 - > measured from top of rebar to bottom of finished V-grooves, and
 - > measured from bottom of rebar to bottom of concrete slab.

C2.1.1.2 Cast-in-place launching ramp slabs are to have an actual 8 inch thickness rather than a nominal thickness. The use of form lumber with nominal width dimensions that are less than design slab thicknesses will not result in meeting the minimum concrete slab thickness and rebar cover requirements. For example, the use of *nominal dimension* 2 inch x8 inch lumber will result in a finished slab only about 7-1/2 inch thick, or less. This would result in almost a 10% reduction in the thickness of the slab.

C2.1.1.3 #4 minimum steel reinforcement (1/2 inch diameter) is to be used on 12 inch centers, both ways. This constitutes temperature steel, but it may not be structurally adequate to support the loads that will occur during the service life of all concrete launching ramp slabs. Slabs must be designed for site specific conditions and constructed in compliance with the design plans and specifications. The rebar must be blocked up on dobies in the forms to



ensure that the final position of the rebar is at the center of the slab depth such that the required 3 inch cover, top and bottom, is provided. Care must be taken to prevent concrete workers from stepping on and dislocating the rebar in the forms prior to and during placement of the concrete.

C2.1.1.4 Epoxy coated rebar is often recommended for use in salt water launching ramp slabs to guard against salt water corrosion of the steel. However, it must be kept in mind that epoxy coatings are vulnerable to scrapes and cuts that can occur during the construction process, subjecting the steel to corrosion along the inside of the external epoxy coating.

C2.1.1.5 Reinforced concrete cutoff walls, not less than 6 inches thick and 24 inches deep measured from the top of the launching ramp surface, should be provided along the head, toe and outside edges of cast-in-place launching ramp slabs unless site soil conditions dictate otherwise. In highly erodible soils, cutoff wall depths may have to be increased up to 36 inches to guard against undercutting during storms and floods. In durable rock foundation material, the cutoff wall depth will have to be determined as directed by the design engineer.

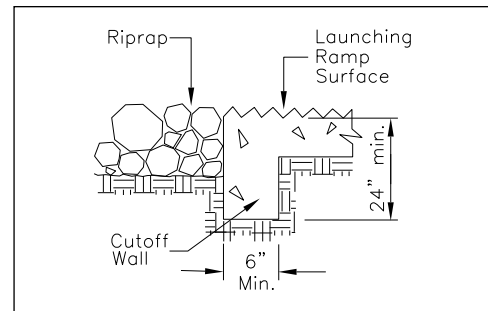

reinforced cutoff walls

C2.1.1.6 Cutoff walls and launching ramp slabs should be built monolithically during the same placement of concrete. Cold joints between the cutoff walls and the launching ramp slab should not be permitted.



flood water undercut launching ramp

C2.2 Precast Concrete Panels

C2.2.1 Precast concrete panels are useful at locations where sites cannot be completely dewatered. They are particularly useful for:

- coastal applications subject to daily tides;
- low-water launching ramp extensions in lakes and reservoirs;
- remote locations where cast-in-place construction is infeasible; and
- temporary launching ramps that can be removed from time to time.



large precast concrete panels being placed

Precast concrete panels are typically 3 to 5 ft wide and 8 inches thick. Precast panels are cast upside-down on a form liner that creates the v-groove texture. A launching ramp designed to have two adjacent launching lanes each 15 ft wide, and 8 ft wide boarding floats along both outside edges, would require precast concrete panels 46 ft long (8 ft + 15 ft + 15 ft + 8 ft = 46 ft). Concrete panels 8 inches thick weigh about 100 pounds per square foot of surface. Therefore, panels 3 to 5 ft wide will weigh from 13,800 to 23,000 pounds. The panels would have to be designed to withstand lifting and handling stresses during manufacture, storage, curing, shipping and final placement at a project site.

C2.2.2 The minimum 3 inch concrete cover above and below the rebar for protection of the reinforcing steel in precast panels is the same as cited for cast-in-place concrete installations in both fresh and salt water. See C2.1.1.1.

C2.2.3 To ensure the long-term alignment and stability of precast concrete panels, cast each panel with a continuous male key along the upslope edge, and a female key along the downslope edge. The male key centered in the middle of the panel edge is stronger and less vulnerable than the flanges of the female key. This method helps to avoid breakage of the keys.



precast concrete panel keys

C2.2.4 Precast concrete panels are subject to undermining. Therefore, the panels must be protected with a 3 to 5 ft wide perimeter of riprap, gunite, geotextile fabrics, and/or other means of durable and reliable erosion protection. The depth of the perimeter protection should be not less than twice the thickness of the precast panels, which would typically be 16 inches minimum. This is a minimum thickness for erosion protection; actual wave conditions at the site shall be considered during design and an appropriate layer thickness of erosion protection shall be incorporated in the design.

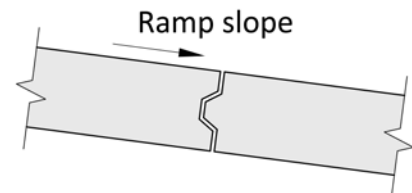

ramp joint orientation

C2.2.5 Installation of precast concrete panels can effectively be accomplished using steel skid rails. The rails can be steel channels, beams or recycled railroad rails. All of the skid rails must be in the same plane at the design slope, accurately aligned and securely anchored in compacted rock base.

C2.2.5.1 Skid rails shall include rail stop at the bottom end of the skid rail. Rail stops shall be welded or securely attached to the skid rail at a 90 degree angle. Rail stops shall be aligned accurately to ensure the bottom edge of precast panels are located and aligned properly.

C2.2.5.2 Skid rails can be installed independently or as part of a prefabricated framework. If independent rails are used, they should be permanently left in place under the panels. If they are pulled out from under the panels after construction, two negative results can occur:

- disturbance of the rock base and the panels; and
- creation of voids under the panels that act as conduits for movement of water resulting in gradual erosion under the precast panels.

C2.2.6 In new construction that includes both cast-in-place concrete and precast panels, the panels should be placed beginning at the lower end of the skid rails, followed by construction of the cast-in-place concrete upslope from the panels. This construction sequence allows the cast-in-place concrete to be placed against and keyed into the upper edge of the top precast panel, providing a smooth seamless joint between the two types of construction.

C2.2.7 If the upper cast-in-place concrete section must be constructed first, locate the bottom edge so that a cast-in-place concrete closure section can be provided between the upper slab and the precast panels. The closure section should be approximately the width of the precast panels, be rebar reinforced, have continuous rebar through the common joint with the upper slab (at least 20 rebar diameters), and finished with the same V-groove pattern used on the cast-in-place upper slab.



closure section under construction



completed closure section

C2.3 Cellular Concrete Mats

Cellular concrete mats are another option for providing boat launching ramps or extending existing launching ramps. Individual concrete blocks are connected together with cables to create mats that are installed as a unit onto a prepared foundation.



flexible cellular concrete mat



upramp view



downramp view

C2.3.1 To support wheel loads, cellular concrete mats shall have a minimum thickness of 6-inches.

C2.3.2 Cellular concrete mats shall not have voids in the block face. Gaps are allowable between adjacent blocks to allow articulation.

C2.3.3 Cellular concrete mats shall be designed with a minimum 30-year service life.

C2.3.4 Cellular concrete mats shall include continuous anchoring along the upper and lower edges; anchoring within the field may be required based on site conditions

C2.4 Concrete Push Slabs

C2.4.1 At some locations it may be feasible and advisable to build launching ramps utilizing 8 inch thick concrete push slabs up to 50 ft wide and 75 ft long. Factors to be considered are:

- the total dead weight of the push slab;
- the launching ramp slope; and
- the size of track-type tractors available to push the slab.

C2.4.2 Push slabs are built on a temporary compacted earth ramp in alignment with and immediately up slope above the design location of the completed launching ramp slab. After the slab has cured, it can be pushed down the slope into the water to its final location, utilizing one or more track-type tractors. 

C2.4.3 A rail-guided push slab must have guiderails properly spaced to effectively guide the push slab, and accommodate the width of a large tractor(s) capable of breaking the push slab loose and pushing it downslope into the water. 

C2.4.4 A rail stop be provided at the bottom end of each guiderail, similar to what is used in precast panel construction. This is particularly important at sites where seismic activity will occur. The first push slab can then be pushed to within a few inches of the rail stop and halted to allow for inspection in the water to ensure that all rock has been cleared from between the lower edge of the push-slab and the rail stop. The push slab can then be gently pushed down the slope until it comes into full contact with the rail stop. 

C2.4.5 Guiderail shall include legs anchored into the ground to prevent movement of the guiderail during the ramp pushing operation. Legs shall be 24 to 36 inches long and shall be welded to each guiderail at the top and bottom of the guiderail. The anchor legs will be vertical and the guide rails will be at the design slope of the launching ramp. Thus, the anchor legs will be welded to the guide rails at an angle dictated by the design slope of the launching ramp.

Leg A (upper leg): Weld a leg under the upper end of each guiderail, with guiderails and anchor legs positioned not less than 12 inches upslope from the upper end of the push slab forms.

Leg B (lower leg): Weld a leg under each guiderail not less than 2 ft upslope from the design location of the upper edge of the push slab after it has been pushed to its permanent design location.

C2.4.6 Sockets 6-8 inches long can be attached at the lower end of each guiderail and at each bottom corner of the push slab. The sockets can be fabricated of steel pipe with an internal diameter that will snugly receive lengths of 1-inch diameter Schedule 40 PVC pipe with colored flags attached at the tops. The angle of the sockets will be determined by the slope of the boat launching ramp. 

C2.4.7 After a slab has been satisfactorily pushed, two choices are in view:

- complete the launching ramp with cast-in-place concrete, or
- construct, cure and push a second slab down against the first slab.

C2.5 Concrete mix specifications for launching ramps should include the following:

- 6 sack concrete
- Type II cement
- 5% air entrainment
- 5,000 psi compressive strength @ 28 days
- water/cement ratio of 0.40
- 3 to 4 inch slump
- 3/4 inch maximum aggregate.

These concrete mix specifications are based on actual design, construction and operational experience on boat launching ramp projects built over the past 40+ years. They provide a contemporary concrete mix that is easy to work, will readily take and hold a V-groove finish, and will result in a strong, durable, functional launching ramp with a long service life.

C2.6 V-Groove Launching Ramp Finish Details

C2.6.1 V-groove finishes are to be provided on all concrete launching ramps to ensure maximum traction for vehicles launching and retrieving boats and trailers. Particular attention is required in salt water where slick marine growth will sometimes be present. Momentary spinning of vehicle tires quickly wears away the growth on the peaks of the V-grooves and grips the launching ramp surface.

C2.6.2 V-grooves have alternating 1 inch 45 degrees faces at 45 degrees, resulting in 90 degrees peaks and valleys. Alignment of V-grooves should be as follows:

- 30 degrees measured from the horizontal toe of the launching ramp lanes; and
- 60 degrees measured from the sloping sides of the launching lanes.

Care must be taken not to reverse the angles, a layout that would result in V-grooves that are too steep and diminish vehicle tire traction on the launching ramp surface.

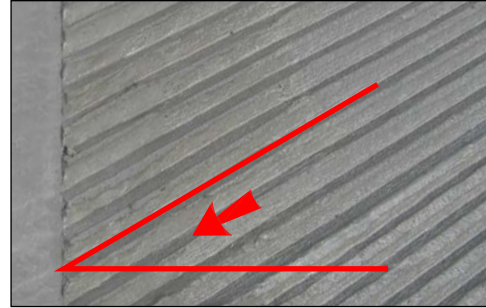

*1 inch V-groove launching ramp finish
note 30° angle of diagonal V-grooves*

C2.6.2.1 V-grooves larger than 1 inch are not necessary. Larger grooves do not provide better vehicle traction and can be difficult to walk on, particularly for persons with small feet such as young children.

C2.6.2.2 V-grooves smaller than 1 inch are more user-friendly to adults and children walking on a launching ramp, but they do not provide the necessary traction for vehicles. Smaller V-grooves are also less efficient in carrying silt and debris off the edge of launching ramps and lanes.

C2.6.2.3 V-grooves as small as 1/2 inch are often provided on launching ramps for non-motorized boats such as kayaks, canoes, inflatables and other small watercraft that do not require launching from a vehicle. 1/2 inch V-grooves are significantly more user friendly for barefoot boaters.

C2.6.3 V-grooves assist in “cleaning” a launching ramp surface in response to boat wakes, wind and storm waves, and rainwater running down the launching ramp. Sand, soil and other debris will tend to be carried down and off the sides of the launching lanes and launching ramp. Therefore, the direction of the V-grooves should be determined in consideration of the following factors:

- topography of the site;
- direction of prevailing wind, waves and currents;
- source of sand, silt and other debris on the launching ramp;
- presence of abutments and boarding floats on the launching ramp; and
- number of launching lanes.

C2.6.4 On wide multiple-lane launching ramps, alternate the direction of the V-grooves from lane to lane to form a “herringbone” pattern.

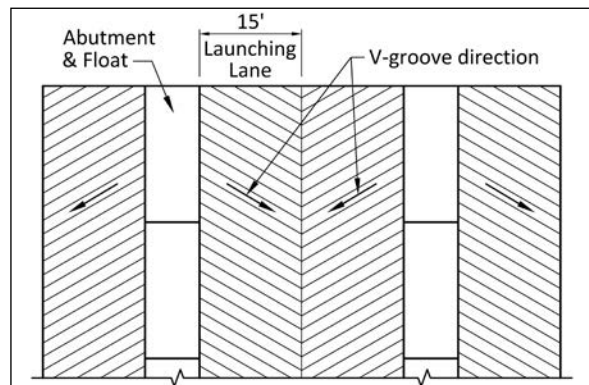

v-groove herringbone pattern

Alternating directional V-grooves along with a 3-inch wide troweled shiny edge finish along the edges of launching lanes (see C1.2.1.3) provides a distinct delineation of the launching lanes. When boarding floats are present V-grooves should angle downslope from the float to prevent vehicles and trailers from drifting into the float if tire traction is lost and tow-vehicle “spins out.”

C2.6.5 V-grooves should not be provided under boarding floats unless the grooves will carry silt and debris under the floats and off the outside edge of a launching ramp. Unless site conditions dictate otherwise, a rough broom finish should be provided under boarding floats. It is a much less abrasive surface for boarding floats to periodically rest on, and will facilitate the movement of silt and debris down the launching ramp and out from under the boarding floats.

C2.7 V-Groove Tool Design and Fabrication

V-groove tool design varies in size, shape, weight, and material used for fabrication. Steel, aluminum and wood tools have been used successfully. However, it appears that aluminum is perhaps the best choice in consideration of tool size, weight, and the ease and speed with which concrete finish crews can produce crisp, straight V-grooves in wet concrete with a slump of 3 to 4 inches on slopes of 12% to 15%. For additional information, review C2.7 V-Groove Tool Design and Fabrication COMMENTARY in Appendix A.

C2.8 V-Groove Launching Ramp Construction Procedure

The successful accomplishment of satisfactory V-grooves by contractors is a continuing problem. It is not an overly difficult task, but contractors who have never performed a V-groove finish on a 12% to 15% slope are consistently overconfident of their skills, abilities, and past flatwork experience of finishing concrete on level sites. Producing satisfactory V-grooves on a slope is a specialized finish process, and must not be considered to be on a par with typical flatwork. Consequently, it is strongly advised that engineers, inspectors and contractors involved in launching ramp V-groove finish work pay close attention to the procedural recommendations in the C2.8 V-Groove Construction Procedure COMMENTARY.



launch ramp construction joint



3-inch shiny edges delineate launching lanes and construction joints

C2.9 Construction Joints

C2.9.1 Construction joints will be necessary at predetermined intervals along the length of a launching ramp and between adjacent launching lanes. The location of construction joints should be clearly addressed on the design plans and specifications with consideration given to the:

- overall length of the launching ramp;
- alignment of the launching ramp;
- number of launching lanes;
- presence of curves, bends or forks; and
- location, positioning and type of boarding floats.

C2.9.2 There should be no “ad hoc” locating of horizontal construction joints based on altered work schedules, lack of planning, convenience, or the whims of contractors and/or inspectors. Adequate equipment, materials and labor must be on site before placement of concrete begins early in the day in order to fully complete a section(s) of a launching lane(s) between planned construction joint locations.

C2.9.3 Construction joints can become reference marks that will eventually be recognized and used by boaters and facility staff to read the water level elevations relative to the length of a launching ramp.

For example, a construction joint is provided at Elevation 840 ft, and the known elevation of the toe of the launching ramp is 830 ft. From just seeing the water line at the construction joint a boater will know that there is still 10 ft of water depth covering the lower portion of the launching ramp. Depending on the slope of the launching ramp within the allowable range of 12% minimum to 15% maximum, the remaining available ramp length will be within the range of:

- 84 ft at 12% slope (8.4 ft of ramp length per foot of water depth); and
- 67 ft at 15% slope (6.7 ft of ramp length per foot of water depth).

C2.10 Weep Holes

Weep holes to reduce or eliminate hydrostatic pressure are not necessary unless a launching ramp is subject to rapid and sustained drawdown of the waterbody. If the water level is known to drop at a rate of 1 ft per hour or more over a sustained period of eight to ten hours, provision of 3 to 4 inch diameter weep holes on 20 ft centers may be necessary. However, due consideration should be given to the slope of the launching ramp, the location of construction joints and the porosity of the aggregate base rock and native soil.

C2.11 Erosion Control Features

C2.11.1 Erosion control features are necessary for all launching ramps and other hardscapes along project shorelines to prevent undercutting by waves, surge, currents and shoreline runoff drainage. Each existing boat launching facility is site specific with regard to what must be done and what it will cost to effectively address or control erosion.



rock rip rap failing at bottom of a lake based boat launching ramp

C2.11.2 With regard to new boat launching facilities, the launching ramps can be protected from erosion by excavating perimeter trenches 3 to 5 ft wide and a minimum of 18 inches deep. Carefully lay geotextile fabric and then place and compact rock riprap. When finished the top of the riprap should be flush with the surface of the launching ramp.

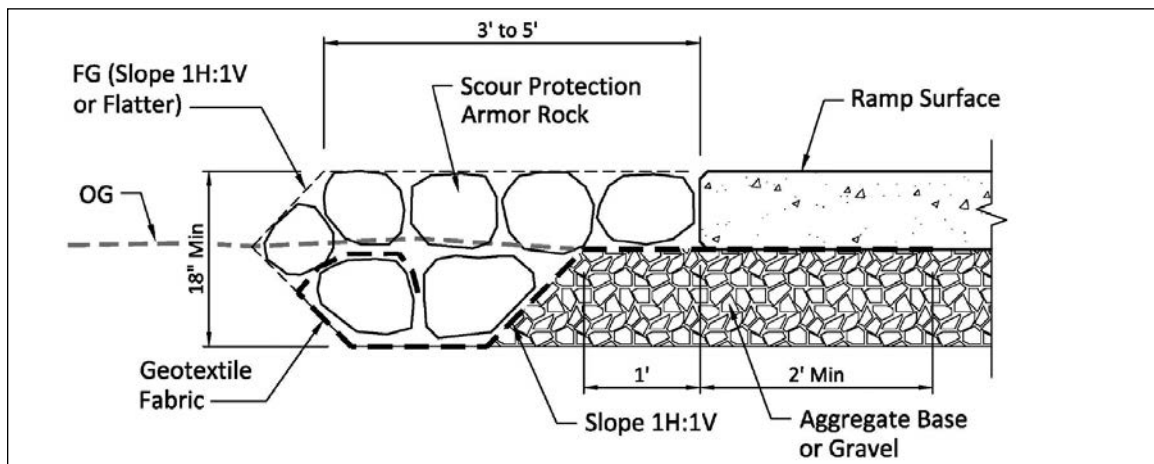

boat launching ramp riprap protection

C2.11.3 At both new and existing boat launching sites, it may be necessary to pump grout into the base rock below the launching ramp through holes drilled through the launching ramp slabs. The number and location of the holes will depend upon the nature and severity of the problem. Pump the grout until it can be seen flowing from under the concrete launching ramp slab out into and up through the perimeter riprap. Additional grout should be spread or blown into the surface of the perimeter riprap to the extent possible above the existing water line. Then clean up and finish the riprap grout surface with a coarse straw broom. “Brooming” of the grouted riprap will help fill the voids and when done skillfully results in a textured surface which is attractive, durable and safe to walk on. Care must be exercised to keep wet grout out of the waterbody for environmental protection reasons.

Section D: Boarding Floats

D1. GENERAL REQUIREMENTS

D1.1 Width Requirements

D1.1.1 Minimum overall width of boarding floats should be not less than 8 ft (96 inches) for new construction. [Note: boarding floats are “**boarding piers**” in accessibility terminology; see definitions in Section A.]

D1.1.1.1 Where existing boat launching facilities have boarding floats at least 6 ft wide, **it is not** recommended that they be replaced with 8 ft wide floats if it would result in narrowing the width of existing launching lanes to less than 15 ft. (see graphic to the right ►)

D1.1.1.2 In no case should boarding floats be less than 6 ft wide. Narrower boarding floats can be somewhat unstable when live loads are applied along one edge.

D1.1.2 Minimum clear travel width should be not less than 5 ft (60 inches) between cleats, bull rails, rings or other mooring hardware mounted along the edges of a boarding float. All mooring hardware should be mounted not more than 6 inches within the boarding float edges.

D1.1.3 Internal Guide Piles

D1.1.3.1 Where internal guide piles are located on or near the centerline of a boarding float, the minimum overall float width should be not less than 8 ft (96 in). The minimum clear width on one side of the pile yoke should not be less than 3 ft (36 in).

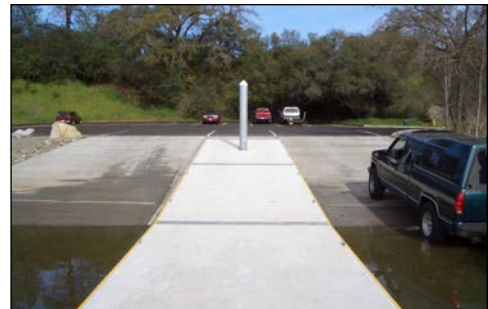

10 ft wide boarding float

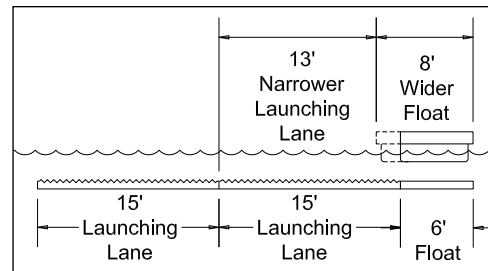

widened boarding float reduces lane width



minimum of 5 ft clear between edge hardware

D1.1.3.2 Where internal guide piles are located to one side of a boarding float, the minimum clear width between the outside face of the pile yoke and the opposite edge of the boarding float should be not less than:

- 4 ft clear (48 in) on 6 ft wide floats, and
- 6 ft clear (72 in) on 8 ft or wider floats.



internal guide piles along edge (left); at center (right)

D1.1.4 External Guide Piles

D1.1.4.1 Guide piles should not be located external to boarding float structural frames along float edges where boats will be passing by or tied up. The presence of external guide piles impairs the free and open utilization of the boarding floats at any point along their edges depending on the number and varying length of boats using the floats. Additionally, external pile yokes protrude into the open water immediately adjacent to the boarding floats, and may cause damage to boat hulls and engines if impacted during launching and retrieving operations.

D1.1.4.2 Utilization of external guide piles may be appropriate where boat access is only possible along one side of a boarding float. In such cases, external guide piles will leave the full width of the boarding floats unobstructed for pedestrian traffic and movement of equipment and supplies to and from moored boats.



external guide piles along outside edge of floats

D1.1.5 Extraneous objects such as trash receptacles, fire hose cabinets, boarding steps, signposts and/or other unnecessary obstacles should not be placed on boarding floats. Such items interrupt the clear space along the edges of boarding floats necessary for the safe and convenient utilization of the floats. Such objects also diminish the clear travel width, obscure vision, and perhaps constitute barriers for persons with disabilities.

D1.2 Length Requirements

D1.2.1 Boarding floats should be long enough to provide not less than 50 ft of float in the water at design low water, measured from the waterline on the launching ramp at design low water to the outboard end of the floats. Water levels below design low water during drought conditions will make it difficult to maintain the 50 ft minimum length.

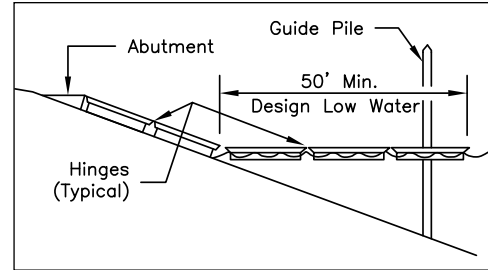

*minimum 50 ft of float
at design low water*

D1.2.2 Where articulated (hinged) boarding float sections are installed, the individual float sections should be not less than 16 ft in length, nor more than 20 ft, with 20 ft being the recommended typical length.



typical 20 ft boarding float section

D1.2.3 At some sites the most remote “terminal” float sections in a string of boarding floats will almost always be floating at low water. Such terminal floats should not be articulated, but rather be structurally continuous without hinges. This provides a more stable terminal float, spreads the live loads more uniformly, prevents reduction of the freeboard and helps prevent the extreme far end from drooping.



non-articulated float section at far end

D1.3 Height Requirements

D1.3.1 **Maximum overall height of boarding floats shall not exceed 30 inches (2 ft-6 in) where float sections will come to rest on a launching ramp surface during periods of low water, and where the “resting” float sections are used for pedestrian access to and from float sections in the water.**



30 inch max. boarding float height

D1.3.1.1 **If it is necessary to exceed a 30 inch maximum height, guard rails shall be provided.** The presence of guard rails makes launching and retrieving boats more difficult and usually interferes with the efficient movement of people, boats and boat lines. Therefore, every effort should be made to keep the overall height of boarding floats to 30 inches or less.

D1.3.1.2 The 30 inch maximum boarding float height does not apply to self-adjusting boarding float systems which operate on raised guiderails and walkways. During low water periods these self-adjusting floats hit rail stop blocks and come to rest on the raised walkways until higher water levels return. Under such conditions the floats are “high and dry”, are out-of-active service and do not provide any pedestrian access.

Therefore, the height is not critical from a safety standpoint and guardrails should not be required. For further comments, see D4.7 Dual-Rail Guided Boarding Floats.



self-adjusting boarding float at rest on launching ramp

D2. LOADING DESIGN CRITERIA

D2.1 Dead Load Only (DLO)

Boarding float sections are to float level in the water within the following limits:

- Length: (slope over length of float section) The length slope should not exceed 0.10 inch (one-tenth inch) per foot over the length of each boarding float section. Along the length of a 20 ft boarding float, the maximum slope should not exceed 2 inches from one end to the other.
- Width: (slope over width of float section) The width slope should not exceed 0.125 inch (one-eighth inch) per foot of width of each boarding float section. Over the width of an 8 ft wide boarding float, the maximum cross slope should not exceed 1 inch from one side to the other.

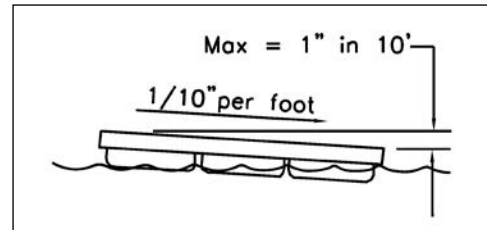

DL level limits – length

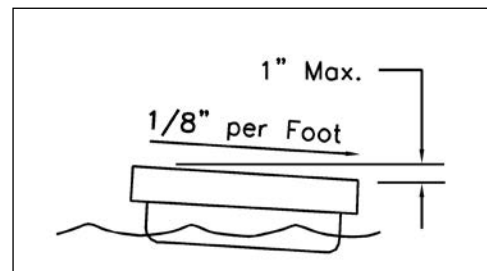

DL level limits – width

D2.2 Uniform Live Loads (ULL)

D2.2.1 20 pounds per square foot (20 psf).

20 psf is a statewide and nationally recognized uniform live load for recreational boarding floats. It is equivalent to a live loading of 20 people each weighing an average of 160 pounds, each occupying 8 square feet of deck space on a 20 ft x 8 ft boarding float.

During an emergency, or a well attended boating event, 20 people on a 20 ft x 8 ft boarding float would each have approximate deck space of:

- a 34 inch square
- a rectangle about 30 inches by 38 inches.

Necessary reasonable space will vary among a mixed presence of adults, children and/or persons with disabilities.

D2.2.2 40 pounds per square foot (40 psf)

For safety purposes, 40 psf uniform live loading shall be applied at boat launching facilities where boarding floats will periodically be used by large numbers of people from buses, ferry boats, boat shows, and/or other short term high activity events.

D2.2.3 ***Whether 20 or 40 pounds per square foot is applied on boarding floats, the same uniform live loading shall be applied to all other boarding float components involved such as gangplanks and gangways.***

D2.3 Live Point Loads (LPL):

D2.3.1 250 pounds (250 lb)

For design purposes, a 250 lb LPL shall be applied at any point on the boarding float deck not closer than 12 inches from the edges along the length of boarding floats. This 250 lb LPL is to be applied concurrently with required uniform live loads.

D2.3.2 450 pounds (450 lb)

For design purposes, where boarding floats are an element on an accessible route, a 450 lb LPL shall be applied at any point on the boarding float deck not closer than 12 inches from the edges along the float length and at the end of the outermost float. The 450 lb LPL is an assumed load based on a 200 pound heavy duty wheelchair occupied by a 250 pound person. The 12 inch offset is based on the estimated center of gravity of a person in a wheelchair near the edge of a boarding float.

D2.3.3 Loads Transferred From Gangways to Boarding Floats

Boarding floats accessed by a gangway must have adequate flotation capacity to receive 50% of the dead and live point loads transferred from the gangway. See D2.7 for gangway loadings on boarding floats.

D2.4 Freeboard

D2.4.1 Dead Load Only (DL)

- 20 inches maximum freeboard
- 14 inches minimum freeboard
- 4 inches minimum freeboard to bottom edge of fenderboard

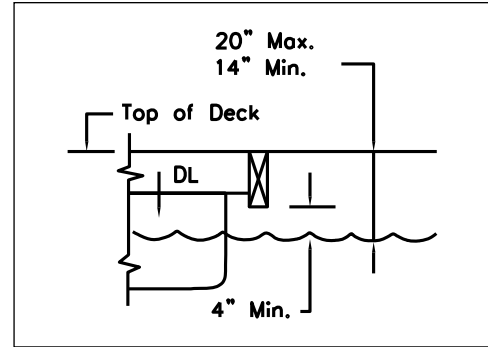

freeboard: DL only

D2.4.2 Dead Load + Uniform Live Load (DL + ULL)

- 10 inches minimum freeboard

D2.4.3 Dead Load + Live Point Load (DL + LPL)

- 13 inches minimum freeboard

D2.4.4 Dead Load + Uniform Live Load + Live Point Load (DL + ULL + LPL)

- 8 inches minimum freeboard

D2.4.5 Special Conditions: For typical large motorized vessels, the standard freeboard as discussed above is used. Low-freeboard boarding floats may be used when non-motorized vessels or small fishing boats are the primary user. Freeboard dimensions will vary in those conditions. For additional information see D2.4.5 Special Conditions COMMENTARY.

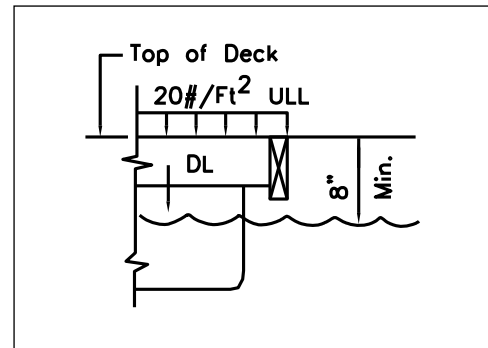

freeboard: DL + ULL

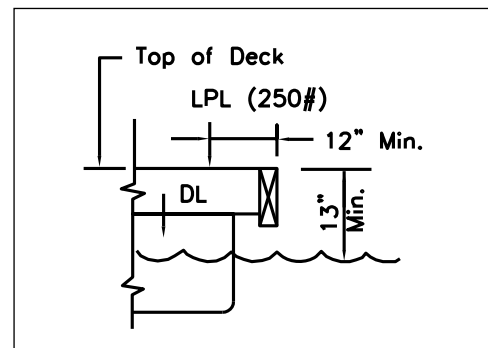

*freeboard: DL + LPL
LPL is 450# on accessible route*

D2.5 Wind, Wave, Current and Impact Loadings

Boarding floats are to be designed to withstand wind, wave, current and vessel impact loadings that may reasonably be expected to occur at a given site during the service life of boarding floats. The loads are to be applied to the boarding floats as well as to boats moored to the floats.

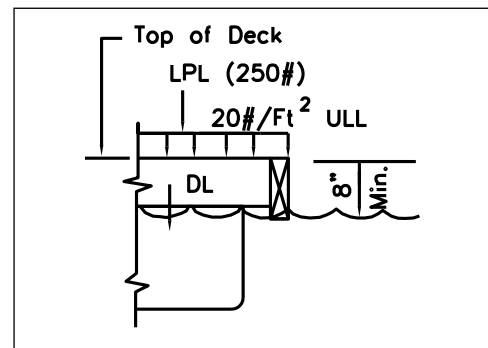

*freeboard: DL + ULL + LPL
LPL is 450# on accessible route*

D2.5.1 Minimum Wind Load Applied to Boarding Floats

- 25 pounds per linear foot (25 lb/ft) of boarding float
 - ☛ Based on a uniform wind load of 15 psf applied to a maximum freeboard exposure of 20 inches (1.67 ft).

D2.5.2 Minimum Wind Loading Applied to Moored Boats

- 45 pounds per linear foot (45 lb/ft) of boarding float
 - ☛ Based on a uniform wind load of 15 psf applied to an estimated in-the-water average 3 ft profile height of trailerable boats.

D2.5.3 Combined Wind Load on Boarding Floats and Boats

- 70 pounds per linear foot (70 lb/ft) of boarding float
 - ☛ Based on the combined wind loadings for boarding floats and moored boats (25 lb/ft + 45 lb/ft). This combined loading is to be applied in designing boarding floats without regard for any “shadowing” effect that may occur from moored boats shielding floats from the wind, currents, impact, etc., or vice versa.
 - ☛ Where boats can be concurrently moored on both sides of a boarding float, applied wind and current loads to boats on the down wind/ current side of the floats may be reduced by 50% and included in the combined wind load.

D2.5.4 Impact Loadings

- Impact loads must be determined on the basis of local conditions.
 - ☛ Based on the type and size of boats typically to be used at or near the boarding floats, the boating activities likely to occur, and the seasonal presence of logs, driftwood and other debris that can be swept into a boarding float and moored boats under various conditions.

D2.6 Deflections



In cases where part or all of a string of boarding floats comes to rest on a launching ramp surface during periods of low water, and such floats continue to provide pedestrian access to and from other floats further down the launching ramp, these floats function as temporary pedestrian bridges. Such temporarily grounded floats should be designed for a L/240 ratio maximum deflection. This will limit the maximum deflection under all applicable dead and live loadings to 0.8 inch on 16 ft long floats, and 1.0 inch on 20 ft floats.

D2.7 Gangplank and Gangway Loadings

D2.7.1 Where boarding floats must support a gangplank, special attention must be given to ensure that adequate flotation is provided to support the dead and live loads on both the boarding float and the gangplank. In some situations it will be necessary to provide flotation under the gangplank near the hinged connection to the boarding float. The shoreward end of the gangplank will be supported by rollers for moving up and down the launching ramp with changes in water elevation.



gangplank access to boarding floats

D2.7.2 In the unusual case of a gangway providing access to and from a boarding float, the various loadings required for gangway design must be considered in the transference of loads to the boarding float.

D3. DESIGN DETAILS

D3.1 Hardware

D3.1.1 Framing Bolts

Framing bolts should be not less than 3/8 inch diameter, and be either hot dipped galvanized steel or stainless steel. Smaller diameter bolts have a too short service life, particularly when installed in pressure treated wood. Hot dipped galvanized fasteners are much more corrosion resistant than zinc plated fasteners. Due to the thickness of the galvanized coating, galvanized bolts will only work with galvanized nuts and washers.

D3.1.2 Ferrous Metals

All ferrous metals used for hardware, clips and other boarding float components are to be hot-dip galvanized after fabrication.

D3.1.3 Minimum Thickness of Metal Plate Components

All metal plates used to fabricate clips, brackets and other structural parts are to be fabricated from material not less than 1/4 inch thick.

D3.1.4 Cleats

D3.1.4.1 Cleats for boat lines should be provided along the edge(s) of boarding floats on centers half-the-length of



boat mooring cleat

individual floats, not to exceed a 10 ft spacing. For example, on 20 ft floats locate cleats 5 ft from each end, resulting in cleats every 10 ft. On 16 ft floats, locate cleats 4 ft from each end, resulting in cleats every 8 ft. On long non-hinged floats longer than 20 ft, provide cleats on 10 ft centers.

D3.1.4.2 Cleats are typically made of ductile cast iron, steel, stainless steel, bronze and aluminum for various uses on boats, docks and piers.

However, for use on boarding floats, galvanized ductile cast iron is probably the cleat of choice for most applications. It is relatively inexpensive, durable and performs satisfactorily. **Do not use cast iron cleats**; they are brittle and break easily, often during installation. All cleats made of ferrous metal must be hot dipped galvanized.

D3.1.4.3 Cleats for boarding floats should have the following characteristics:

- heavy duty cleats in lieu of light weight cleats;
- 8 to 10 inches in length, tip to tip of cleat horns;
- bearing base not less than 2 to 3 inches wide and 4 inches long;
- secured with two (2) hex head galvanized machine bolts;
- machine bolts to be not less than 7/16 inches in diameter; and
- hex head bolts to fit flush into recesses in the top of the cleats.

D3.1.4.4 Cleats should be thoroughly cleaned with a wire wheel, and all burrs and rough spots ground smooth to prevent chafing of boat lines and boater's hands.

D3.1.4.5 When designing boarding floats with dissimilar metal materials, caution must be taken to avoid electrolysis. An example would be cast iron cleats fastened to an aluminum deck. It is suggested that the dissimilar metals be separated with thin gaskets made of durable nylon/plastic materials suitable for the purpose.

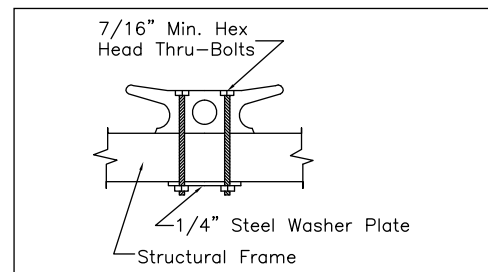

galvanized steel backup washer plate

D3.1.4.6 Cleats should be double-bolted through the main frame of the boarding float. Do not use lag screws to secure cleats. If larger cleats are required for larger boats, it is recommended that galvanized steel backup washer-plates be used, large enough to receive both cleat bolts on the bottom surface of the float frame.



recessed mooring ring

D3.1.4.7 Although bull rails and rings are sometimes used in lieu of cleats, bull rails are no longer allowed for new construction.

D3.1.5 Support Legs and Pontoon Skids

D3.1.5.1 In cases where boarding floats periodically come to rest on a launching ramp, support legs or other protective devices must be installed to protect the flotation pontoons. At various water levels, the outboard end of a boarding float section resting on a launching ramp just above the waterline can be repeatedly raised and dropped by incoming waves, resulting in the float being continuously hammered on the launching ramp. This repeated action can continue for several hours or even days, and can destroy the flotation pontoons and damage the launching ramp finish.

Steel support legs can be bolted directly to the boarding float frame and fitted with ultra-high-molecular-weight (UHMW) plastic pads 1/2 inch or thicker. The legs have to be long enough to hold the flotation pontoons clear of the launching ramp surface by a couple of inches, but not so long as to violate the 30 inch maximum boarding float height requirement (see D1.3.1). This necessitates careful design of boarding floats, including frame depth, how pontoons are attached to the frame, pontoon depth, length of support legs and thickness of leg pads.

D3.1.5.2 In most cases, support legs should be attached to the down-ramp end of boarding floats, but not to the up-ramp end. However, if the floats are designed to be periodically removed and stored, support legs would be necessary on both ends for stacking and storage. An example would be a location subject to severe winter freezing that captures and damages boarding floats in winter ice.

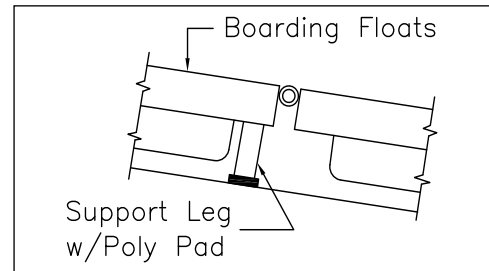

support leg upslope from hinge

D3.2 Decking

D3.2.1 Decking materials commonly used on boarding floats include composite plastics, fiberglass, pultruded fiberglass, aluminum, steel and concrete.

D3.2.2 Decking should perform well in marine environments, be durable and have a service life of not less than 15 years, depending on the location and climate. Decking material selected should meet the following criteria:

- resistant to cracking, splintering, dry rot, decay and insect damage;
- resistant to fresh water, saltwater and ultraviolet damage;

- not needed to be treated or painted; and
- have good foot and equipment cart wheel traction.

D3.2.3 Accessible Decking Requirements

D3.2.3.1 *Gaps between adjacent decking members shall be perpendicular to the length of boarding floats, and shall not exceed 1/2 inch in width.*

D3.2.3.2 Changes in decking level up to 1/4 inch maximum between adjacent decking members are permitted to be vertical. *Changes in level between 1/4 inch and 1/2 inch maximum shall be beveled with a slope not steeper than 1:2 (1 unit vertical to 2 units horizontal). Combined vertical and beveled changes in decking level in excess of 1/2 inch shall not be permitted.*

D3.3 Pontoons

D3.3.1 Boarding float pontoons should be rigid enclosed vessels completely filled with marine grade flotation foam. Such pontoons typically are either rectangular or circular in cross section. In choosing a pontoon, keep in mind that rectangular tubs and circular pipes have different flotation characteristics.

D3.3.2 Rectangular Pontoons Suggested Design Characteristics:

- made of rotationally molded medium density polyethylene (MDPE);
- black in color;
- **0.15** inch minimum wall thickness;
- completely enclosed on all four sides, top and bottom;
- 100% foam filled;
- 100% watertight; and
- integrated fastener flanges for attachment to boarding float frames.



rectangular "tub" pontoons

D3.3.3 Circular Pipe Pontoons Suggested Design Characteristics:

- made of high density polyethylene;
- black in color;
- **0.035** inch minimum wall thickness;
- dual wall construction --- smooth bore pipe inside corrugated pipe;
- interior smooth bore pipe 100% filled with a polystyrene plug; and
- fitted with securely fastened polyethylene end caps.



*circular "pipe" pontoons and end cap(s)
polystyrene plugs not shown*

D3.3.4 Pontoon Flotation Foam



Flotation foam shall be placed inside all rigid pontoon shells, even those that are considered to be watertight. The foam will increase the rigidity and stability of the shells, and is relatively inexpensive insurance in the event water enters the shell through puncture holes, cracks, joints or seams.

D3.4 Fender Boards

D3.4.1 Fender boards have the following functions:

- protective interface between boarding floats and boats;
- base member for attachment of bumper materials, cleats and rings;
- protection of pontoons from impacts, debris, boats, vandals, etc.; and
- replaceable edge trim strip for decking.

D3.4.2 Fender boards can be an integral element in a boarding float structural frame, or can be a “sacrificial member” that is attached external to the structural frame. There are pros and cons for either of these two alternatives.



D3.4.3 The material of choice for sacrificial fender boards on newly constructed boarding floats is high density polyethylene (HDPE) plastic lumber which has the following attributes and advantages:

- low maintenance;
- ultraviolet resistant;
- exceptionally tough and durable;
- available in range of dimensions;
- not generally abrasive to boat hulls;
- typically no additional bumper material is needed;
- provides excellent protection to the float frame and pontoons; and
- available in bright colors to improve the visibility of the floats for safety (yellow is the preferred color).

D3.4.3.1 Although HDPE plastic lumber is expensive, it is durable if fastened properly and has good visibility from boats approaching the boarding floats. Special detailing is necessary to provide oversize or slightly slotted bolt holes and bolt head recesses that will allow for seasonal thermal expansion and contraction of the polyethylene material so that it will not buckle, crack or break. Follow the manufacturer’s recommendations to address expansion and contraction characteristics.

D4. TYPES OF BOARDING FLOAT SYSTEMS

D4.1 Non-Floating Boarding Platforms

D4.1.1 Non-floating boarding platforms are movable wedge-shaped structures built to conform to the slopes of specific launching ramps so as to provide stable level decks. They rest on a launching ramp surface and stay in place by virtue of their heavy dead weight. Typically constructed of steel, they have retractable wheels, are fitted with trailer hitches, must be repositioned up and down the launching ramp as water levels change, and can easily be removed from the water for maintenance and winter storage.



non-floating boarding platform

D4.1.2 Non-floating boarding platforms are practical at locations where some or all the following situations exist:

- water levels do not change rapidly;
- soil conditions prohibit driving guide piles;
- winter ice requires the removal of boarding floats; and/or
- operational staff is available to move boarding platforms as required.

D4.2 Suspended Non-Floating Boarding Platforms

D4.2.1 Suspended non-floating boarding platforms usually consist of structural steel or aluminum frames, decking and suspended pairs of piles at the ends of the platforms. Individual platform sections are typically 16 to 20 ft long and are connected with full platform width hinges. The entire suspended structure is “yo-yoed” up and down with hoists and cables as water levels dictate. Access to and from shore is typically via a gangplank or a gangway.



4 sections of suspended platforms

D4.2.2 Suspended platforms are only practical at sites where seasonal water conditions are too severe for use of conventional floating boarding floats, and the range of annual water level fluctuations does not exceed 10 ft.

D4.2.3 Suspended platforms can be raised several feet clear of the water surface for winter storage to avoid damage from wind and storm waves in open water locations on shallow lakes and bays. This eliminates storm damage to the platforms, piles and pile yokes that is common on floating boarding floats in

rough water locations. When hoisted up for winter storage, the platform sections must be secured laterally to the suspension piles to avoid wind sway and banging against the piles. Pedestrian barricades and signs must also be put up to prevent people from going out onto the platforms when they are not in service.

D4.3 Pile-Guided Articulated Boarding Floats/Fixed Abutment

D4.3.1 Pile-guided articulated boarding floats consist of a series of individual 16 to 20 ft long float sections hinged together end-to-end, hinged to a fixed abutment on shore, and held in alignment by a row of guide piles. Secured to the abutment, the floats are designed to rotate vertically as they rise and fall with changing water levels. This means that the upper float sections will progressively “ground out” by coming to rest on the launching ramp surface while the lower float sections remain floating. The number of floats grounded out and floating will change as water levels rise and fall with tides and seasonal changes in bays, rivers, lakes and reservoirs.

D4.3.2 Articulated boarding floats are practical in coastal applications, rivers and lakes with annual water level fluctuations up to 16 ft, measured from the elevation of the abutment hinge down to the water level. This will ensure that both the abutment and boarding float freeboard requirements are included in the determination of the overall required boarding float length. Beyond this 16 ft threshold, the total required length of the boarding floats and the number and height of the guide piles become cost prohibitive and impractical. This is the type of boarding float that is most commonly used in California tidal waters and low fluctuation lakes and reservoirs.



articulated boarding floats

D4.3.3 Articulated boarding floats can be used on waterways that exceed 16 ft in annual water fluctuations by providing additional guide piles and a portable abutment that can be relocated up and down the launching ramp along with the boarding floats. A shorter string of floats can be used, but they must be un-yoked from the guide piles, moved up or down the launching ramp, and re-yoked, a process that is labor intensive and highly impractical if water levels change rapidly or frequently.

D4.3.4 Articulated boarding floats can be used at river sites that are subject to periodic flooding and total inundation of the launching ramp, abutments, parking lots, etc. However, the abutments must be designed to float upward on the guide piles along with the boarding floats, and come back to rest on the launching ramp surface when the water drops back to normal levels. Such abutments must have internal flotation adequate to keep the abutments level in the water. If allowed to

excessively droop or hang from the upper end of the first boarding float section, an abutment will point down toward the ramp surface and jam against it as water levels drop. This can result in severe jamming and twisting as the dead weight of the boarding floats imparts progressively greater destructive forces, resulting in severe damage to the abutment, the connecting hinge and the upper end of the first float section. Once this happens, it is difficult and dangerous to undo it, usually requiring a crane. The pieces have to be lifted, hinge pins removed, repairs made, and the system restored to normal working condition.

D4.4 Cable-Guided Boarding Floats

D4.4.1 Cable-guided boarding floats are usually 50 to 100 ft long and move up and down exceptionally long boat launching ramps. Guided by steel cables as seasonal water levels rise and fall, this type of float is typically used on high drawdown lakes and reservoirs. This type of float must be adjusted periodically, and designed to come to rest on the launching ramp surface during periods of extremely low water. Such periods may last for a few days, weeks, months, or sometimes years during extended multiyear droughts as experienced in California during back-to-back seven year droughts in the 1970s and 1980s.

D4.4.2 Cable-guided boarding floats are usually constructed using two or more float sections hinged together. A long non-hinged boarding float will not satisfactorily work at most locations in lakes and reservoirs. This is primarily because of the behavior of the float during low water periods when it will of necessity gradually come to rest on the lower end of the launching ramp as water levels fall, and gradually lift up off the launching ramp as water levels rise. In both cases, float hinges relieve the bending stresses that occur when the upper end of the float is resting on the launching ramp and the lower end is floating in the water. The greater the launching ramp slope, the greater the potential float bending stress. Such situations last until the float is completely at rest on the launching ramp when water levels are dropping, or fully afloat in the water when water levels are rising.



cable-guided boarding float

D4.4.3 The guidance cable should be 5/8 inch minimum diameter. The cable should be high quality stainless steel or galvanized steel wire rope, depending on salt water or fresh water environments. The cable must be tightly stretched between cable anchors at the top and bottom of the launching ramp in order to maintain the alignment of a boarding float at various water levels.



D4.4.4 Cable guided boarding float systems are practical for installation on straight launching ramps in waterbodies with annual water level fluctuations of more than 20 ft. Such cables must be straight and tight to function properly. Therefore, guidance cables cannot effectively be used on launching ramps with dog legs or large sweeping curves, unless:



overlap of two guidance cables

- two (or more) individual guidance cables are used in straight stretches with an appropriate overlap at their point(s) of intersection, including extra cable boxes; this necessitates detachment and reattachment of the boarding float from/to the upper and/or lower cables as water levels require; or
- a cable is tightly stretched and anchored on a long sweeping moderately curved launching ramp such that [1] the cable diagonally crosses over adjacent launching lanes, and [2] a boarding float moving up and down the cable would occupy part or all of different launching lanes at different water levels; this necessitates unhooking and rehooking the boarding float from/to the cables at specific water elevations when water levels rise and fall; or
- a cable is stretched and “stitched down” along the edge of a curved launching ramp by hooks, rings or clips at intervals of 50 to 100 ft, depending on the length and degree of the ramp curvature; this necessitates the use of pairs of “pig tail” drop cables (permanently attached to the guidance cable between points where the cable is stitched down) for attaching and reattaching the fore and aft ends of the float at various water levels.

D4.5 Single-Rail Guided Boarding Floats

A single-rail guided boarding float system is similar to the cable guided system described above, with the exception that a steel rail is used in lieu of a cable. The



single-rail steel beam guided boarding float



trolley is made of a slotted steel pipe with multiple types of wheels attached to pipe-rail and trolley



wheeled trolley being tested on a steel pipe rail guidance system --- boarding float not shown

rail is constructed of steel beams or steel pipe, and is mounted on supports and brackets that adequately elevate the rail and securely attach it to the launching ramp. The upper end of the boarding float is attached to the rail with short lengths of chain attached to trolleys which freely run up and down the rail in response to changes of water levels. This system is useful on long launching ramps in waterbodies with large annual drawdown, and is particularly suited for launching ramps with curves. The pipe-rail system, pictured below on the right, has been successfully used on curves with radii as tight as 85 ft. A turntable, as seen in the middle picture below, is necessary to allow horizontal articulation of the gangplank and boarding float for freedom of movement up and down the curves with changing water levels. It is necessary to stabilize and guide both the upper and lower ends of the gangplank and boarding float using adjustable brackets and chains for connections to the trolleys.

D4.6 Dual-Rail Guided Boarding Floats



D4.6.1 Dual-rail boarding float systems are similar to single-rail systems. However, the guide rails, guidance hardware and float structures are more complex. Two types of dual-rail systems that have worked well are described below.

D4.6.1.1 Dubbed Model 1970-X, a dual-rail system was developed in the early 1970s that generally consists of a raised concrete walkway, steel channel guiderails embedded in the vertical sides of the raised walkway, an underwater truss, support legs, wheels, a two-unit hinged steel boarding float frame, flotation pontoons, decking and a gangplank. The 5 ft wide raised walkway is 12 to 14 inches high. The upper end of the float structure and gangplank attach to the guiderails with fixed legs, axles and wheels. The ends of the hinge at the mid-point of the float structure connect to the upper ends of the underwater truss. The truss extends diagonally down into the water from the hinge at about 30 degrees from horizontal, connects to the guiderails with axles and wheels, and self-adjusts in response to waves and foot traffic.

The entire system moves up and down the guiderails with falling and rising water levels and is designed to gradually come to rest on the raised walkway if necessary during low water conditions. Of necessity, the truss is designed

*dubbed model
1970X dual-rail
boarding float*



to laterally hold the outer end of the boarding float in alignment with the raised walkway, and to have clear openings through which the flotation pontoons can pass when the whole structure gradually settles down to rest on the walkway. Flanges on the sides of the fixed legs on the upper end of the float are designed to come into contact with stop plates welded on the webs of the embedded guide rails. At low water, the stop blocks arrest the downward movement of the float system and hold it in place so the float will not come off the lower end of the guiderails. The flanges and stop blocks must be precisely designed and built to allow passage of the float and truss past the stop blocks to allow the downward movement to be arrested at the top end of the float, not the bottom. By gravity, it will “hang” on the walkway stop blocks until water levels rise and lift the float system upward along the slope of the raised walkway and launching ramp.



dubbed 2008 dual-rail guided boarding float

D4.6.1.2 Dubbed Model 2008-DRF, this “dual-rail system” was developed in 2008 to replace the Model 1970s-X dual-rail float system. It generally consists of a 5 ft wide raised concrete walkway with embedded guiderails similar to the previously described dual-rail float system, three steel boarding float frames, support legs with wheels at the corners of all three float frames, flotation pontoons, fibergrate decking, two underwater trolleys and a gangplank.

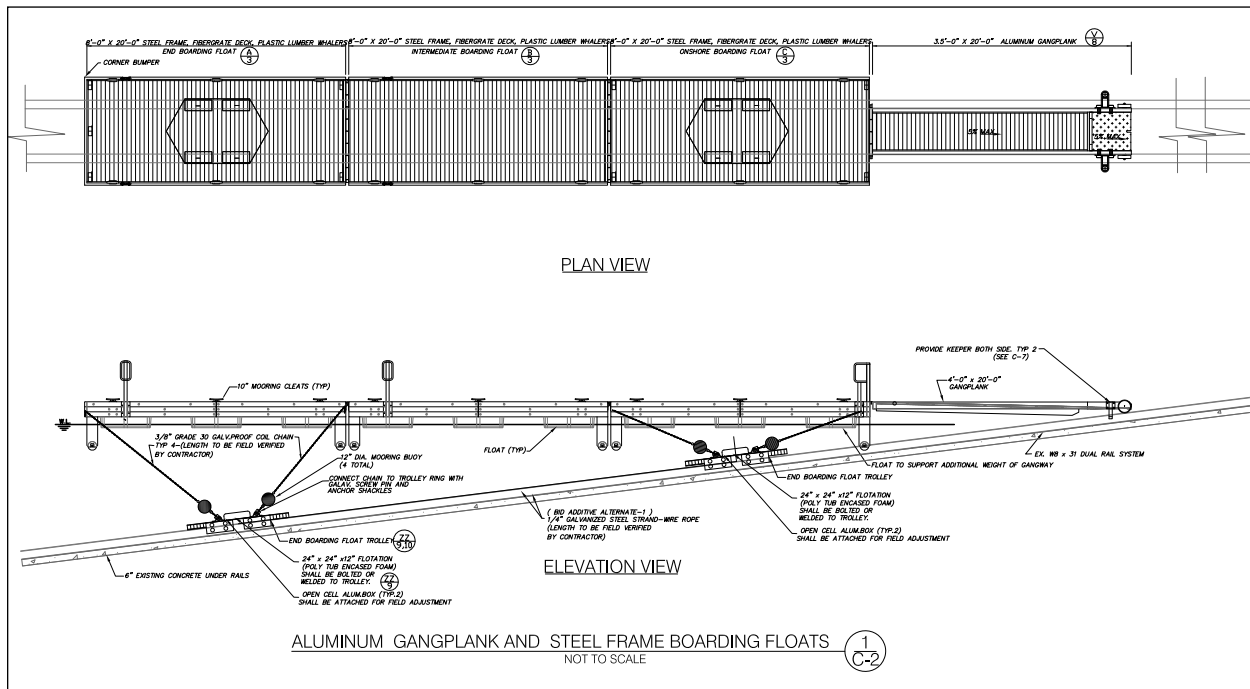

model 2008X dual-rail boarding float



trolleys



raised walkway with guiderrails



gangplank



dual-rail boarding float



Sawpit Ramp Silverwood Lake



dual-rail boarding float

The 8 ft wide, 60 ft long boarding float consists of three 20 ft float units hinged together. The upper end of the first float frame is hinged to a 20 ft gangplank, the upper end of which is fitted with roller/wheel assemblies that connect to the guiderrails. The steel legs and wheels on the three 8 ft wide float frames straddle the 5 ft wide raised walkway when the float system comes to rest on the launching ramp surface during low water periods.

Centered below the 1st and 3rd float sections are trolleys with wheels and rollers that operate flush with and immediately above the raised walkway and guiderrails. Each of the trolleys is fitted with [1] a foam-filled flotation tub; [2] two adjustable air/water ballast tanks with plugs used to balance the buoyancy of the trolley to enable it to move freely on the guiderrails; and [3] four adjustable length chains that connect diagonally to the ends of the boarding float section immediately above. Properly adjusted chains and tuned ballast tanks provide boarding float decks that are flat and level. This complex float system works very well, freely moving both up and down the guiderrails with changing water levels. The upper and lower ends of both trolleys are equipped with "V" shaped debris plows that clear the surface of the raised walkway and help keep the trolley wheels and rollers clear and unjammed.

D5. ABUTMENTS

D5.1 General Requirements

D5.1.1 The length of an abutment will vary with the slope of the launching ramp. The steeper the launching ramp, the shorter the abutment length. Lengths range from about 17 ft on 15% launching ramps up to about 21 ft on 12% launching ramps.



boarding float abutment

D5.1.2 The overall width of an abutment is to exactly match the overall width of the boarding floats hinged to an abutment. This is to provide a smooth transition line between the abutment and floats, free of any shoulders or edges sticking out into the travel path of pedestrians, vehicles and/or boats.

D5.1.3 The location of an abutment relative to the head of a launching ramp will vary with the topography, slope of the launching ramp, and the elevation difference between design high water and the maneuvering apron above the head of the ramp.



D5.1.4 To protect abutments and boarding floats from backing trailers and vehicles, bright yellow 4 to 6 inch diameter heavy steel pipe bollards with caps may be anchored in concrete a few feet up from the beginning of the abutments. Where such bollards will interfere with maintenance and vehicle access to the top of the abutments, removable bollards can be inserted into steel pipe sleeves anchored in concrete. Where abutments are tied into raised walkways with curbs, bollards should not be provided.

D5.1.5 The upper end of an abutment must be “feathered” into the pavement, walkway or other pedestrian access route so as to provide a smooth transition to and from the abutment.

D5.1.6 ***An abutment on an accessible route shall comply with the requirements for maximum slope, minimum width and surface texture. Exceptions apply to the accessible route but not to the abutment and boarding floats.***

D5.1.7 ***A boarding float abutment shall not exceed a maximum height of 30 inches measured perpendicular to the surface of the launching ramp at the face of the abutment. Where an abutment height must exceed 30 inches, guardrails and handrails shall be provided along the full length of both sides of the abutment.***

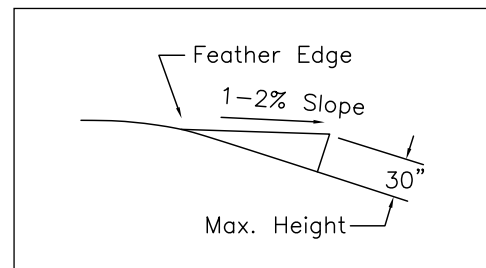

30 in. maximum abutment height

D5.1.8 Boarding floats are not required to have guardrails and handrails. Since an abutment is a transition element between the shore and a boarding float, a boarding float abutment is not required to have railings either, unless its height exceeds 30 inches as stated in D5.1.7 above. The same maximum height safety guideline criteria applies to boarding floats (see Section D1.3.1).

D5.1.9 The abutment face (at lower end) is to be constructed:

- vertical: where hinge hardware is embedded in top edge of the abutment; and
- perpendicular: to the slope of the launching ramp below the hinge hardware.

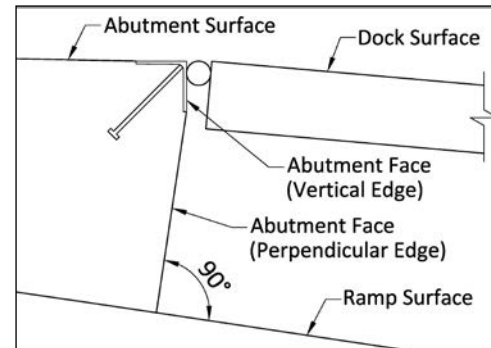

abutment face

D5.1.10 ***Where an abutment is located along an outside edge of a launching ramp, and riprap or other revetment materials are over 30 inches below the top of the abutment, guardrails shall be provided along the full length of the outside edge of the abutment.***

D5.2 Design Details

D5.2.1 Abutments are typically constructed of reinforced concrete.

D5.2.1.1 Abutment concrete should have a minimum compressive strength of 4,000 psi, and be reinforced with not less than #4 deformed reinforcing steel bars.

D5.2.1.2 The abutment surface should receive a rough broom finish perpendicular to the direction of traffic to provide appropriate traction. If other construction materials are used, the surface traction must be not less than that provided by a rough broom finished concrete abutment.

D5.2.2 In new construction, concrete abutments should be formed and the concrete placed at the same time the adjacent launching lane is built, resulting in a monolithic abutment/launching ramp structure, free of any cold joints between the launching ramp slab and the abutment. This will ensure that the abutment will be thoroughly anchored, will not move under any normal loadings applied, and will protect against intrusion of corrosive fluids such as sea water which will rust the reinforcing steel.

D5.2.3 In fresh water locations, rebar cover should be not less than 2 inches; and in salt water locations, 3 inches of cover, the same criteria used for launching ramp construction.

D5.2.4 Where an abutment is being added to an existing launching ramp, the footprint of the new abutment must be cleaned by sand blasting or chiseling of the surface to facilitate bonding with the new concrete. The ramp surface is also to be drilled and vertical rebar dowels secured in the holes with epoxy for anchoring the abutment rebar cage.



boarding float-abutment hinge

D5.2.5 All horizontal and vertical edges of an abutment should be rolled over or chamfered 1 inch at 45 degrees. This will help guard against chipping of the edges, and will provide less abrasive edges that may be bumped into by people, boats, trailers and equipment.

D5.2.6 Abutment surface drainage should be toward the boarding floats at a slope of 1 to 2%. This will also help diminish the “hump” effect at the abutment hinge when the boarding floats are resting on the launching ramp surface during periods of low water. If particular site problems dictate the need for an abutment cross slope, it should not exceed 2% (1:50). However, for practical construction purposes, use a maximum cross slope of 1/4 inch per foot (1:48 / 2.08%) which is only slightly steeper than a 2% cross slope. Most people would not be able to perceive or discern the difference between a 2% and a 2.08% slope.

D5.2.7 Boarding float/abutment hinges should be 2 inch diameter extra strong steel pipe. The hinge barrels and flanges should be continuous, without any gaps, and cut flush with or slightly inside the sides of the abutment and the boarding float. The top surface of the hinge barrel must be flush with the top of both the abutment and the boarding float deck. Weld the hinge barrels on the abutment side of the hinge to a 1/2 x 4 x 6 inch steel angle. Weld 12 inch J-hooks at 45 degrees on 12 inch centers along the inside corner of the angle for anchorage in the concrete abutment. Hot-dip galvanize the entire hinge assembly after fabrication.

D6. GUIDE PILES

D6.1 General Requirements

D6.1.1 Guide piles are typically used with boarding floats at locations where the annual water level fluctuation is 16 ft or less.

D6.1.2 Boarding float guide piles are normally used in three cross sectional shapes:

- Round in steel pipe or concrete;
- Octagon in concrete only; and
- Square in concrete only.

D6.1.3 After piles have been driven to or cut off at the required elevation, they should be capped with fiberglass or polyethylene cone-shaped pile caps with a wall thickness not less than 1/8 inch. Pile caps shall include a reflective coating or reflective tape around its perimeter with a nominal width of 3 inches.



guide pile with “cone” cap

D6.1.4 Pile caps dress up the appearance of the launching ramp, protect the top ends of the pilings, prevent trash and other objects from being tossed into open-ended steel piles, and discourage the roosting and nesting of birds on top of the piles. Bird droppings are unsightly, cause slippery deck surfaces, and are highly corrosive to metal parts on both boarding float pile yokes and moored boats. Extra care must be taken to adequately secure pile caps to the piles to prevent theft. Marine grade epoxies used in adequate quantities usually work well with proper pile and cap surface preparation.

D6.2 Design Details

D6.2.1 It is recommended that the minimum cutoff elevation for boarding float piles be not less than design high water, plus the boarding float freeboard, plus 6 ft (72 inches), excluding the height of pile caps. Considering that boarding float freeboard under dead load only can range up to 20 inches, the length of guide piles extending above design high water will be upwards of 8 ft (96 inches).

D6.2.2 On very stable, sheltered waterbodies with very little annual or seasonal water level fluctuation, 6 ft of pile above the deck at low water may be too conservative. However, ***the cutoff elevation shall never be less than design high water plus boarding float freeboard plus 4 ft above the deck.*** Guide piles shorter than this can become hazards on the boarding floats for persons who might fall over or stumble on such a low profile obstacle, especially at night or during a rain storm.

D6.2.3 Where guide piles are used on boarding floats in rivers and other waterbodies subject to flood stage water levels that exceed design high water, the boarding floats should be designed and built for removal from the water if it becomes necessary. The guide piles must be tall



removable exterior pile yokes around steel guide piles

enough to provide not less than 4 ft of piling visible above absolute high water. Such piles may very well catch and collect a certain amount of debris, but they also may be valuable for temporarily securing search and rescue watercraft, patrol boats and repair barges. In no case should “short” piles be provided that will be submerged at flood stage. Such piles can punch holes in boat hulls and be a hazard to personnel who may have to work in or near the water under emergency flood conditions.

D6.2.4 If it is necessary to use steel guide plies in salt water, great care must be taken to select the proper steel alloy, structural thickness and pile coating to ensure a minimum 20-year pile service life.

D6.2.5 Square concrete piles must have chamfered corners, and the exposed face in the casting forms must be finished with a smooth steel trowel finish similar to the three formed faces. This requirement is necessary to provide a smooth non-abrasive surface for pile yoke rub strips and rollers to work against, and to provide a more pleasing uniform appearance.



square concrete guide pile

D6.2.6 Care must be taken when driving square and octagonal concrete piles to prevent rotation as they are driven. In their final position they must be square with the alignment of the boarding floats and pile yokes. Otherwise the piles, pile yokes and boarding floats will not properly function together as water levels change and the floats ride up and down on the piles.

D6.2.7 In applications where steel piles and steel pile yokes are used together, durable vertical rub strips should be attached to the piles. This will prevent abrasive wear to pile coatings, and minimize steel-on-steel clanging noises that will occur on windy days and during storms. Steel-on-steel clanging can be heard over great distances and becomes highly annoying to boaters, campers, nearby residents and others within earshot, particularly at night.

D7. PILE YOKES

D7.1 General Requirements

D7.1.1 Pile yokes are typically steel structural frames that “capture” guide piles to keep boarding floats in position on a launching ramp. The yokes are usually curved in cross section, i.e., a steel pipe yoke; or have flat surfaces that can be fitted with pile rollers or rub strips for the protection of both the guide piles and the pile yokes. Pile yokes ride up and down on the faces of guide piles as water

levels change, hold boarding floats in position and in alignment, and transfer horizontal loads between the boarding floats and guide piles. The sources of these horizontal loadings include wind and storm waves, currents, ebb and flood tidal flows and impacts from moored boats, boats underway and floating debris.

D7.1.2 Exterior yokes and interior yokes are the two common types of boarding float pile yokes, local site specific conditions being the determining factor. Exterior yokes attach to the exterior faces of the boarding float structural frames, and are wholly outside the perimeter of the boarding floats. Interior yokes are framed openings within the structural frames and the perimeter of the boarding floats.

D7.2 Exterior Pile Yokes

D7.2.1 Exterior pile yokes work well on boarding floats where boats can be launched, retrieved and moored only along one side of the floats.



exterior pile yoke

Typical examples:

- A boarding float is located along either side of a single-lane launching ramp, and the side of the boarding float opposite the launching ramp is inaccessible by boat; or
- A boarding float is located along the outside edge of an outside launching lane on a multiple-lane launching ramp. Limited or no boat access along the outside edge can be caused by a shoreline configuration that prohibits boat access at some or all water levels. It can also be caused by operational requirements/regulations of local authorities who have utilized buoy lines, signs or other devices to limit the access in response to some site specific condition such as a swimming beach adjacent to the boat launching facility.

D7.2.2 Advantages of exterior pile yokes:

Advantage #1: The full width of the boarding floats is usable by boaters and free of any obstructions to the movement of people, equipment and gear.

Advantage #2: The side of the boarding floats along which boats are launched, retrieved and moored is uninterrupted and may be fully utilized by boats of various lengths at any point along the entire length of the boarding floats.

Advantage #3: Removal of one or more boarding floats for repair, seasonal storage or replacement does not require lifting the floats up and over the guide piles.

D7.2.3 Disadvantages of exterior pile yokes:

Disadvantage #1: The attachment of exterior pile yokes, especially heavy ones, disturbs the symmetrical balance of the dead load weight of boarding floats in the water. This results in shifting the center of gravity from the boarding float centerline toward the yoke side of the floats. Unless some counterbalance measure is taken, the boarding floats roll slightly in the water toward the yoke side, causing cross slope problems, a decrease in the yoke side freeboard, and an increase in the opposite side freeboard. The bigger and heavier the pile yokes, the greater the shift and changes in cross slope and freeboard.

Disadvantage #2: Exterior pile yokes are prone to catch trash and floating debris, particularly in rivers that carry high spring runoff often filled with large tree branches, logs, and other floating objects.

D7.3 Interior Pile Yokes

D7.3.1 Interior pile yokes work well on boarding floats where boats can be launched, retrieved and moored along both sides of the boarding floats.

Typical examples:

- boarding floats with launching lanes along both sides of the floats; and
- boarding floats located along the outside edge of an outside launching lane of a multiple lane launching ramp where the shoreline configuration allows safe and convenient access to the outside edge of such boarding floats.

D7.3.2 Advantages of interior pile yokes:

Advantage #1: Internal pile yokes are integral with the float structural frame. They are actually framed openings within the boarding float rather than a separate component attached to the outside edge of a float. Thus, internal yokes cannot come into contact with and cause damage to boats being launched, retrieved or moored.

Advantage #2: Internal pile yokes are more compatible with the overall dead weight balance of a boarding float. Locating pile yokes inside the perimeter and structural frame helps maintain a level float system with little or no cross slope under dead loading.



interior pile yoke flush with deck



interior pile yoke with raised curb

D7.3.3 Disadvantages of interior pile yokes:

Disadvantage #1: Internal pile yokes reduce the clear width of boarding floats, somewhat reducing their usability. Also, internal piles make it more difficult to repair and/or replace floats, particularly on docks with centerline piles. On boarding floats less than 8 ft wide, interior pile yokes should be located to one side of the float just inside the structural frame to provide adequate width for pedestrian traffic. Where a boarding float is on an accessible route, the minimum allowable clear width is 60 inches to allow turning movements.

However, accessibility requirements permit the width to be 36 inches along the accessible route for a distance not to exceed 24 inches (ADA 1003.3.1

Exception 1). This presents a problem where centerline pile yokes must be longer than 24 inches on boarding floats hinged to an abutment and subject to high water fluctuations. See Section D7.6 for an example of addressing boarding float lateral movements in conjunction with fixed guide piles.

Solution to Disadvantage #1: On floats 8 ft wide (96 inches) and wider, piles and pile yokes can be located along the centerline, providing at least 36 inches of clear width along both sides of the pile yokes and up to 24 inches for the width of the centerline piles and pile yokes (36 inches + 24 inches + 36 inches = 96 inches). The 24 inch maximum allowable length along the 36 inch wide accessible route along both sides of the piles can be addressed by providing pile yoke cover plates. The cover plates must have holes (typically round or square depending on the piles) large enough to freely accommodate the piles and have smooth edges so as not to abrade the pile faces. Also, the plates have to be flush with the boarding float deck, or not exceed a height of 1/2 inch. Cover plates over 1/4 inch high must be chamfered above 1/4 inch. Additionally, the cover plates must be designed to stay centered on and in alignment with the pile yokes. This can be accomplished by providing guide strips along the underside edges of the cover plates that will slide along the edges of the pile yokes but still be clear of the piles. The cover plates must be long enough to cover the pile yoke openings at all water levels. They must also freely slide along the top of the yokes as changing water levels alter the position of the floats and yokes relative to the permanent positions of the piles and cover plates.



sliding pile yoke cover on round pile



sliding pile yoke cover on square pile

Disadvantage #2: Internal pile yokes are in close proximity to people who walk and carry various items along the boarding floats. Since an internal yoke is really nothing more than an opening in the boarding float, it presents the opportunity for someone to accidentally step or fall into the opening.



Solution to Disadvantage #2: Provide either raised curbing around a pile yoke opening, not to exceed 4 inches in height and 2 inches in width, or preferably a sliding pile yoke cover plate on pile yokes with openings large enough for someone to step into. 4 inch raised curbs are allowable (ADA-ABA 1003.3.2 Exception 2) along the edges of boarding floats on accessible routes. Curbs around interior pile yokes along the edges of boarding floats can be considered extensions of the edge protection. The cover plate described in the Solution to Disadvantage #1 above address this situation as well.

D7.4 Pile Yoke Rollers and Rub Strips

D7.4.1 Pile yoke roller assemblies and rub strips are mounted either on pile yokes or directly to the vertical sides of boarding floats. They are secured to galvanized steel roller assemblies or frames bolted directly to the boarding float structural frames. The actual rollers and rub strips function as sacrificial interfaces between pile yokes and guide piles. It is much easier and less expensive to change rollers and rub strips than to repair or replace piles and pile yokes.

D7.4.2 Rollers and rub strips must be made of tough non-abrasive material that is durable, pliable, tolerant of repetitive impact loading without deformation, and resistant to heat, freezing and ultraviolet deterioration. It is recommended that pile yoke rollers and rub strips be made of ultra high molecular weight (UHMW) polyethylene with black ultraviolet light inhibitor added. Roller axles should be 3/4 to 1 inch diameter stainless steel, drilled at each end for stainless steel cotter pins, and mounted in galvanized steel roller brackets.

D7.4.3 Rollers mounted on rectangular pile yoke frames work well on square and octagonal cross section concrete piles with smooth flat bearing faces upon which rollers can make full length contact. This will promote balanced roller wear around its circumference and throughout the roller length, insuring a good service life. Specifications for square and octagonal concrete piles must specify that all pile faces be formed or steel trowel finished to provide smooth pile faces suitable for operation of pile yoke rollers.



pile yoke rub strips



UHMW pile yoke roller



D7.4.4 Rollers are not recommended for use with round guide piles. A roller is a horizontal cylinder and a round pile is a vertical cylinder. When brought together in a “pile against roller” contact, the two cylinders at 90 degrees to each other will “kiss” at a very small point of contact, and over time the roller will gradually wear into an hour glass profile with a thin waist, reduced middle diameter and a shortened service life. Additionally, such hour glass shaped rollers facilitate transfer of lateral pile/roller loads parallel to the roller axle that will accelerate wear and eventual ruin of the rollers. This is a particular problem at sites with strong surge conditions that cause repetitive reversals of horizontal float movement that grinds the rollers against piles, ruining the rollers and perhaps damaging the yokes and piles as well. The provision of square pile yokes and rub strips will greatly reduce the above described problems.



pile rollers wearing against round pile

D7.4.5 Pile yoke frames, rollers and/or rub strips must be designed and built with the following characteristics in mind:

- rollers and rub strips secured with bolts, lock washers and nuts;
- fasteners to be field accessible for tightening or replacement of parts;
- yoke frames and bolt heads will never come into contact with piles;
- roller assemblies cantilevered to make rollers prominent in openings;
- rub strips thick enough for long wear; and
- all rub strip bolt heads and washers countersunk not less than 1/2 inch.

D7.4.6 Pile yoke dimensions are determined by the following factors:

- dimensions of the piles and size characteristics of rollers or rub strips;
- standard 1 inch minimum pile clearance at all rollers and rub strips;
- minimum pile yoke opening for safety of boaters; and
- maximum pile yoke opening to facilitate maintenance access and safety.

D7.5 Pile Yoke Design Details

D7.5.1 In cases where articulated boarding floats are hinged to fixed concrete abutments, the string of hinged boarding floats will rotate about the abutment hinge as water levels rise and fall. This dynamic rotation results in lateral movement of the floats relative to the fixed vertical positions of the guide piles. The guide piles do not move, but the boarding floats do.

The extremes occur when:

- (a) high water causes boarding floats to be horizontal and perpendicular to the guide piles; and

(b) extreme low water causes boarding floats to come to rest on the sloped surface of a boat launching ramp, temporarily leaving the floats and the pile yokes at a slope ranging between 12% [1:8.33] and 15% [1:6.67] (see C1.7) The greater the distance between an abutment and a pile, the greater the relative lateral displacement between the pile and the two ends of each pile yoke.

D7.5.2 Rectangular pile yoke frames, with full length rub strips mounted on the two long sides of the frames, are necessary to provide adequate length inside each pile yoke to ensure that the pile never binds against either end of the yoke at extreme high or low water. Such yoke frames provide a straight, flat and suitable base for rub strips working against square, octagonal or circular piles. If designed and constructed correctly, the ends of the rectangular pile yokes will never come into contact with the guide piles. All yoke-to-pile contact will be along the long sides of the pile yokes.

D7.5.3 Recommended clearance between a guide pile and pile yoke rub strips is 1 inch along each side and 4 inches **minimum** at each end.



D7.5.3.1 Where pile yokes have a deep profile, as in the case of an internal boxed pile yoke framed with 6, 8, 10 or 12 inch deep structural members (composite plastic lumber, metal, etc.), additional clearance must be provided between the pile face and the lower edge of the down-slope end of the pile yoke opening. This additional clear opening space is necessary to maintain a minimum 4 inch clearance when the boarding float rotates downward as water levels drop. It is recommended 1/4 inch per inch of pile yoke depth be added to the down-slope clear opening as a pile yoke depth factor. So, if the pile yoke depth is 10 inches, add an additional 2-1/4 inches to the pile yoke clearance (1/4 inch X 10 = 2-1/4 inch).

D7.5.4 Square pile yoke frames with rollers or full length rub strips mounted on all four sides of the yoke frame are preferred for use on boarding floats not attached to abutments and that do not come to rest on launching ramp slopes at lower water levels. In such cases there is no lateral movement of the floats in the water, and square pile yokes work very efficiently.



D7.5.5 Pile yoke frames have traditionally been round or square. Round galvanized steel "pile hoops" have been used extensively for decades to secure floating docks to wood piles. Extending out from the edge of floats somewhat like a fish landing net, the round hoops are compatible with the round cross section of wood piles, and if installed properly will function for many years without excessive wear on the yokes or piles. However, with the



square pile yoke with rub strips

emergence of concrete and steel piles, the use of steel pile hoops has diminished. The bare steel hoops do not work well against bare steel or concrete, and both the hoops and piles become abraded and worn, and can be very noisy during periods of strong winds and rough water.

D7.6 Pile Yoke and Boarding Float Rotation

D7.6.1 Boarding floats attached to an abutment will gradually rotate about the abutment hinge as the water level falls, daily and seasonally. At both coastal and inland launching ramp sites, it is common for boarding floats to “ground out” on the launching ramp surface as the water level drops. The boarding float hinged to the abutment will ground out first, and then in series the other floats will progressively ground out depending on the extent of the water level drop. When this happens one or more boarding floats will assume the slope of the launching ramp, thus requiring adequate length of opening in the pile yoke to accommodate the rotation of the boarding floats relative to the static vertical guide pile.

D7.6.2 Boarding Float Rotational Displacement Example Problem.

The following example problem illustrates how to use Table D7.6.2 to accurately determine the critical inside dimensions of a rectangular pile yoke. The table addresses the horizontal distance from the center of an abutment hinge pin to the centerline of a guide pile. Distances are given in 4 ft increments from 16 to 160 ft for launching ramps with slopes ranging from 12.0% to 15.0%, in 0.5% increments. For exact distances and slopes different from the values shown, interpolation will provide values that are well within tolerable limits.

EXAMPLE PROBLEM:

Use Table D7.6.2 to determine the pile yoke clear opening dimensions for the following case:

- 13.5% ramp slope
- 12-inch diameter pile
- 10-inch pile yoke depth
- 88 ft from center of abutment hinge pin to centerline of pile
- 1-inch minimum side clearance, each side of pile (2 inches total)
- 4-inch minimum end clearance, each end of pile yoke opening

Clear Opening Width:

$$= 12 \text{ inch} + [1 \text{ inch} \times 2] = \mathbf{14 \text{ inches clear opening width}}$$

Clear Opening Length:

$$\begin{aligned} &= \text{pile diameter} + \text{end clearances} + \text{rotational displacement} + \text{pile yoke depth factor (see highlighted value in Table D7.6.2 for rotational displacement)} \\ &= 12 \text{ inch} + [4 \text{ inch} \times 2] + 9.6 \text{ inch} + [1/4 \text{ inch} \times 10] \text{ (see D7.5.3.1 for yoke depth factor)} \\ &= 12 \text{ inch} + 8 \text{ inch} + 9.6 \text{ inch} + 2.5 \text{ inch} = \mathbf{32.1 \text{ clear opening;}} \\ &\text{thus, } \mathbf{\underline{\underline{use 32 inches}}} \end{aligned}$$

Final Result:

Pile Yoke Design Clear Opening = 14 inch wide by 32 inch long

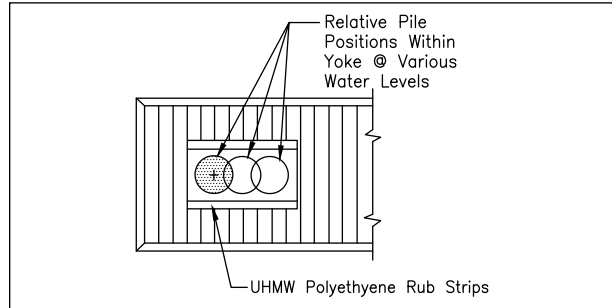
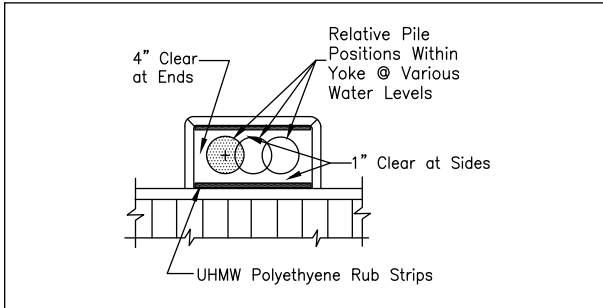

pile yokes stretched to allow boarding floats to rotate on an abutment hinge and move laterally along the vertical sides of guide piles as water levels rise and fall

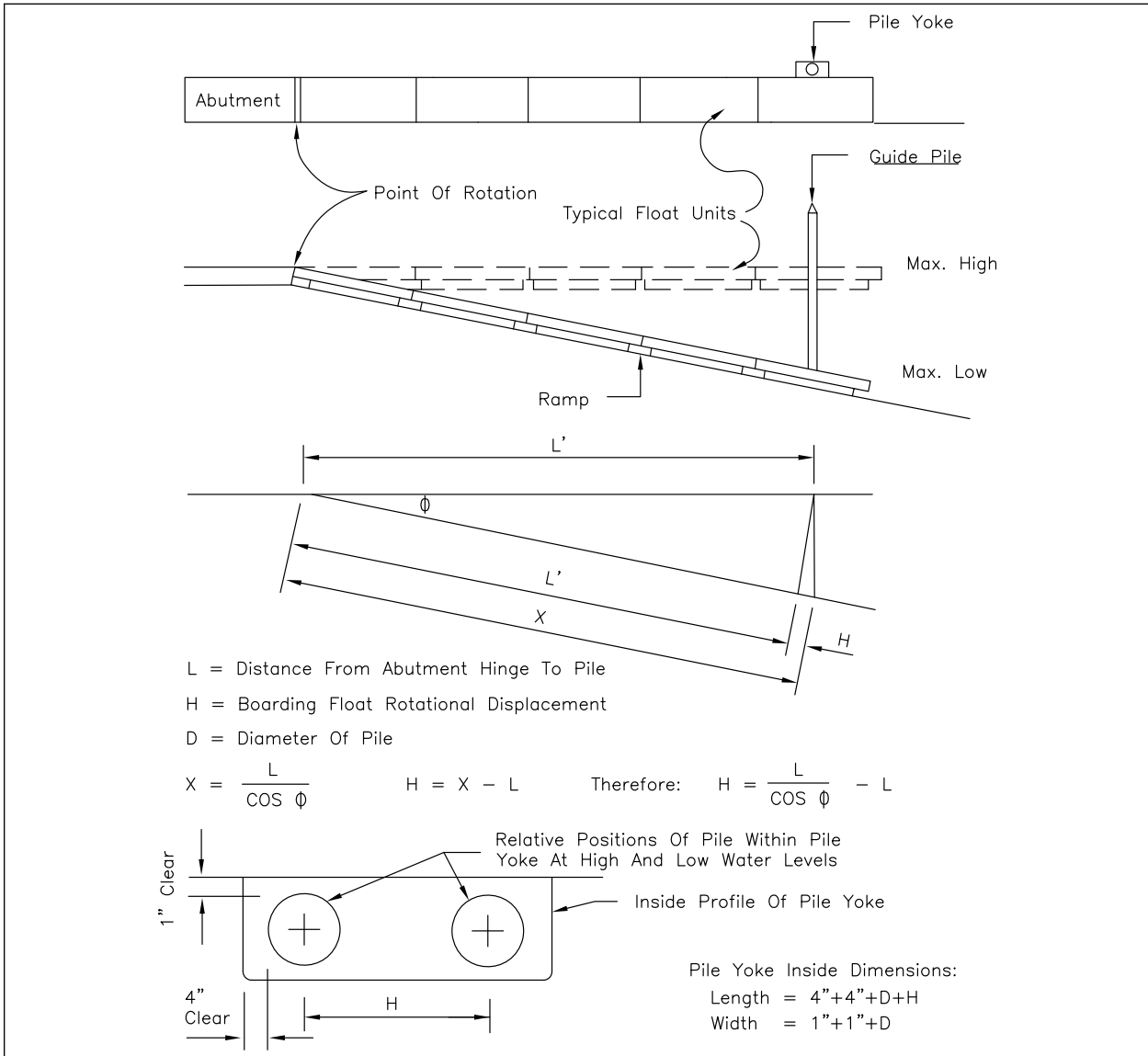

boarding float displacement diagram – basis of Table D7.6.2

Table D7.6.2 Boarding Float Rotational Displacement

| H = Horizontal Rotational Displacement | | | | | | | |
|--|-------------------------------------|----------------|----------------|----------------|----------------|----------------|-----------------|
| % Slope | 12.0 | 12.5 | 13.0 | 13.5 | 14.0 | 14.5 | 15.0 |
| ∅ | 6°50'34" | 7°07'30" | 7°24'25" | 7°41'18" | 7°58'11" | 8°15'01" | 6°31'51" |
| Cos ∅ | 0.99288 | 0.99228 | 0.99166 | 0.99101 | 0.99034 | 0.98965 | 0.98894 |
| L (ft) | H = [(L/Cos ∅) – L] x 12 (inches) | | | | | | |
| 16 | 1.4 | 1.5 | 1.6 | 1.7 | 1.9 | 2.0 | 2.1 |
| 20 | 1.7 | 1.9 | 2.0 | 2.2 | 2.3 | 2.5 | 2.7 |
| 24 | 2.1 | 2.2 | 2.4 | 2.6 | 2.8 | 3.0 | 3.2 |
| 28 | 2.4 | 2.6 | 2.8 | 3.0 | 3.3 | 3.5 | 3.8 |
| 32 | 2.8 | 3.0 | 3.2 | 3.5 | 3.7 | 4.0 | 4.3 |
| 36 | 3.1 | 3.4 | 3.6 | 3.9 | 4.2 | 4.5 | 4.8 |
| 40 | 3.4 | 3.7 | 4.0 | 4.4 | 4.7 | 5.0 | 5.4 |
| 44 | 3.8 | 4.1 | 4.4 | 4.8 | 5.2 | 5.5 | 5.9 |
| 48 | 4.1 | 4.5 | 4.8 | 5.2 | 5.6 | 6.0 | 6.4 |
| 52 | 4.5 | 4.9 | 5.2 | 5.7 | 6.1 | 6.5 | 7.0 |
| 56 | 4.8 | 5.2 | 5.7 | 6.1 | 6.6 | 7.0 | 7.5 |
| 60 | 5.2 | 5.6 | 6.1 | 6.5 | 7.0 | 7.5 | 8.1 |
| 64 | 5.5 | 6.0 | 6.5 | 7.0 | 7.5 | 8.0 | 8.6 |
| 68 | 5.9 | 6.3 | 6.9 | 7.4 | 8.0 | 8.5 | 9.1 |
| 72 | 6.2 | 6.7 | 7.3 | 7.8 | 8.4 | 9.0 | 9.7 |
| 76 | 6.5 | 7.1 | 7.7 | 8.3 | 8.9 | 9.5 | 10.2 |
| 80 | 6.9 | 7.5 | 8.1 | 8.7 | 9.4 | 10.0 | 10.7 |
| 84 | 7.2 | 7.8 | 8.5 | 9.1 | 9.8 | 10.5 | 11.3 |
| 88 | 7.6 | 8.2 | 8.9 | 9.6* | 10.3 | 11.0 | 11.8 |
| 92 | 7.9 | 8.6 | 9.3 | 10.0 | 10.8 | 11.5 | 12.3 |
| 96 | 8.3 | 9.0 | 9.7 | 10.5 | 11.2 | 12.0 | 12.9 |
| 100 | 8.6 | 9.3 | 10.1 | 10.9 | 11.7 | 12.5 | 13.4 |
| 104 | 8.9 | 9.7 | 10.5 | 11.3 | 12.2 | 13.1 | 14.0 |
| 108 | 9.3 | 10.1 | 10.9 | 11.8 | 12.6 | 13.6 | 14.5 |
| 112 | 9.6 | 10.5 | 11.3 | 12.2 | 13.1 | 14.1 | 15.0 |
| 116 | 10.0 | 10.8 | 11.7 | 12.6 | 13.6 | 14.6 | 15.6 |
| 120 | 10.3 | 11.2 | 12.1 | 13.1 | 14.0 | 15.1 | 16.1 |
| 124 | 10.7 | 11.6 | 12.5 | 13.5 | 14.5 | 15.6 | 16.6 |
| 128 | 11.0 | 12.0 | 12.9 | 13.9 | 15.0 | 16.1 | 17.2 |
| 132 | 11.4 | 12.3 | 13.3 | 14.4 | 15.5 | 16.6 | 17.7 |
| 136 | 11.7 | 12.7 | 13.7 | 14.8 | 15.9 | 17.1 | 18.3 |
| 140 | 12.1 | 13.1 | 14.1 | 15.2 | 16.4 | 17.6 | 18.8 |
| 144 | 12.4 | 13.4 | 14.5 | 15.7 | 16.9 | 18.1 | 19.3 |
| 148 | 12.7 | 13.8 | 14.9 | 16.1 | 17.3 | 18.6 | 19.9 |
| 152 | 13.1 | 14.2 | 15.3 | 16.5 | 17.8 | 19.1 | 20.4 |
| 156 | 13.4 | 14.6 | 15.7 | 17.0 | 18.3 | 19.6 | 20.9 |
| 160 | 13.8 | 14.9 | 16.1 | 17.4 | 18.7 | 20.1 | 21.5 |

D8. GANGPLANKS

D8.1 General Requirements

D8.1.1 Since almost all gangplanks will be accessible under the terms of federal accessibility guidelines, it is recommended that the design guideline criteria in D8.2 below be used for all gangplanks that provide access to boarding floats located on boat launching ramps.

D8.1.2. Gangplanks are provided (1) only on self-adjusting boarding floats that necessarily move up and down along the slope of a boat launching ramp with changing water levels, guided by cables or rails; and (2) on boarding floats in flood zones that ride unusually high up on piles during flood periods. Neither of the above situations is suitable for the use of traditional concrete abutments.



boarding float gangplank

D8.2 Accessible Gangplanks

D8.2.1 Gangplank Guidelines

A “gangplank” is not defined or in any way recognized in federal and/or state accessibility guidelines. Consequently there are no gangplank design requirements in the 2010 ADA Standards by which gangplank accessibility compliance can be judged. However, “GANGPLANK” is defined and addressed in these GUIDELINES and should be utilized as an accessible element under the guideline criteria below.

D8.2.2 Minimum Number of Accessible Gangplanks

D8.2.2.1 The 2010 ADA Standards do not require that boarding floats be provided at boat launching ramps. But where boarding floats are provided, at least 5%, but not less than one, must be accessible (see 2010 ADA Standards Section 235.3). Note that the only situation in which the 5% factor would apply would be where there are at least 21 boarding floats at a particular boat launching ramp facility. One boarding float would meet the 5% requirement for up to and including 20 boarding floats.

D8.2.2.2 It is recommended that all gangplanks be accessible. The total number of self-adjusting boarding floats on a particular boat launching ramp is rarely more than two or three because of the depth of the waterbodies where self-adjusting boarding floats are used. The typical long lengths of the launching ramps, cables or rails, and the terrain often limits the number of

launching lanes and the overall width of the launching ramps. Therefore, it is prudent and practical to make all gangplanks accessible. This will enhance the usability of the boarding floats for everyone, make the overall facility more accessible, and will be practical for maintenance and repair because of uniformity of components and interchangeability of parts.

D8.2.3 Accessible Gangplank Slope

Maximum Slope: 5% (1:20)

D8.2.3.1 Since gangplanks are not recognized and defined in the 2010 ADA Standards, most permitting agencies and officials will interpret a gangplank to be either a walking surface, or a ramp.

- A “walking surface” cannot exceed a slope of 5% (1:20).
- A “ramp” is greater than 5% in slope, but cannot exceed 8.33% (1:12).

D8.2.3.2 *Gangplanks that exceed a slope of 5% shall meet the various accessibility standards for ramps, including maximum slope, cross slope, run, rise, edge protection, guardrails and handrails.*

D8.2.3.3 Keeping a gangplank at or under a maximum slope of 5% will provide highly accessible access to and from a boarding float for people with disabilities as well as for adults and children of all ages and abilities.

D8.2.4 Gangplank Width

Required Minimum Width: 36 inches clear

Recommended Width: match width of boarding float (clear width is reduced due to edge protection rails)

D8.2.4.1 The required minimum 36 inch clear width is the minimum clear width requirement for accessible ramps and walking surfaces [see 2010 ADA Standards Sections 403.5.1 (walkways) and 405.5 (ramps)].

D8.2.4.2 The recommendation to match the gangplank width to the width of the boarding float is considered to be practical design in consideration of the nature of the recreational boating activity that will occur and the pedestrian traffic that will be present. The minimum clear width of accessible boarding floats is 60 inches (see 2010 ADA Standards Section 1003.3.2). But for functional reasons,

boarding floats are typically 72 to 96 inches wide for stability, two-way pedestrian traffic, and reasonable access to boats tied to opposite sides of the floats.



matching width of gangplank and float

Matching the gangplank and boarding float widths provides the following advantages:

- smooth uninterrupted path of pedestrian travel;
- continuity of alignment along both edges;
- eliminates vertical drops at shoreward end corners of boarding floats;
- eliminates corners that can catch on boats, trailers and vehicles;
- is particularly beneficial when vision is obscured by darkness, vehicle headlights, fog and/or stormy weather conditions; and
- provides 36 inch minimum clear width each side of centerline guide cable.

Notice in the last “■ advantage” listed above that matching the width of a gangplank to the width of the boarding float provides at least 36 inches clear on both sides of a guidance cable which typically passes under and along the centerline of a gangplank and boarding float. This optimizes the accessibility of moving between the surface of a launching ramp and a gangplank. Guidance cables are typically 5/8 inch to 7/8 inch in diameter and may constitute a barrier if someone is required to cross over such a cable when moving to or from a gangplank.



gangplank with centerline cable

D8.2.5 Maximum Cross Slope: 2%

This is the same maximum cross slope applied to other accessible elements such as ramps and walking surfaces.

D8.2.6 Handrails

D8.2.6.1 By definition in these GUIDELINES (see page 12) gangplanks that do not exceed a slope of 5% are not required to have handrails. The presence of handrails obscures visibility, gets in the way of open vehicle doors, complicates the free and easy use of boat lines during normal boat launching and retrieval, and can cause safety problems for drivers, pedestrians and equipment.



gangplank edge protection

D8.2.6.2 A gangplank that exceeds a slope of 5% will be interpreted to be a “ramp” and will be required to meet the various requirements for accessible ramps including guardrails and handrails.

D8.3 Design Details

D8.3.1 Edge Protection

D8.3.1.1 A raised curb approximately 3 to 4 inches wide and 4 inches high should be provided along both edges of gangplanks.

D8.3.1.2 The curb should be gradually tapered from full height at the leading edge of the gangplank to flush deck height at the hinge between the gangplank and boarding float.

D8.3.2 Decking

D8.3.2.1 Gangplank decking should be non-skid in character, consisting of structural surface treatments (grooves, knurling, ridges, etc.) or fine aggregate coatings (epoxy with silicon carbide grit, etc.) that will provide safe use in both wet and dry conditions. The decking surface should be aggressive enough to provide appropriate foot traction but not so aggressive as to cause injury if a person falls on it.

D8.3.2.2 Any open joints or gaps in the gangplank decking shall be aligned perpendicular to the path of pedestrian travel. All such joints must be flush and even across the full width of the gangplank.

D8.3.2.3 A 5% maximum gangplank slope should not need deck treads. However, at higher elevations where fall, winter and spring ice may be

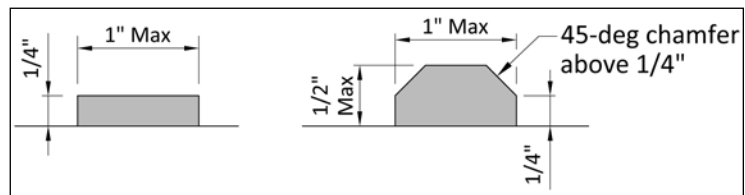

gangplank treads

present, treads may be necessary and appropriate. If necessary, treads must be securely fastened to the gangplank decking and should be coated with a durable gritty coating to facilitate non-slip footing when ice is present.

D8.3.2.4 If needed, gangplank treads should be on 12 inch centers, not exceed 1 inch in width, and shall not exceed 1/2 inch in height. Where treads exceed 1/4 inch in height, the vertical tread faces shall be chamfered 45 degrees above the 1/4 inch thickness.

D8.3.3 Leading Edge

D8.3.3.1 The height of the leading edge of a gangplank shall not exceed 1/2 inch, measured from the top edge of the gangplank to the surface of the launching ramp. Where a gangplank is positioned over a V-groove launching

ramp surface the measurement is to be taken to the top edges of the V-grooves.

D8.3.3.2 Any gangplank leading edge thickness in excess of 1/4 inch shall be chamfered 45 degrees above the 1/4 inch thickness at a slope not to exceed 1:2 (vertical to horizontal).



1/2 inch max gangplank leading edge

D8.3.3.3 It is recommended that replaceable polyethylene full gangplank width wear strips be provided along the bottom of the leading edge. The leading edge of a gangplank will typically rest directly on a launching ramp surface, usually concrete, a rough and abrasive surface by its very nature. As a self-adjusting boarding float moves up and down the launching ramp with changing water levels, the gangplank will “drag” downhill and “plow” uphill, abrasive actions in both cases. If left unprotected the leading edge will gradually wear to a thin edge and have to be repaired or replaced. The polyethylene wear strip will help mitigate this abrasive action and prolong the service life of a gangplank. The leading edge thickness guidelines above apply jointly to both the gangplank plate and the wear strip.



gangplank lifted up to see cable slot and wear slip



6 inch gangplank wearstrip wedge



leading edge of gangplank

D9. GANGWAYS

D9.1 General Requirements For Application At Boat Launching Ramps

D9.1.1 Gangways are not recommended for access to boarding floats on launching ramps as they typically are required to have both guardrails and handrails. The railings obscure a boater’s vision, get in the way of vehicle doors, and prevent the free and easy use of boat lines when launching and retrieving trailer boats. However, if a site-



Case #1. gangway and boarding float **ARE NOT ON** launching ramp

specific determination has been made that a gangway is necessary to provide pedestrian access on an accessible route to and from a boarding float, two distinct cases are as follows:



*Case #2. gangway and boarding float **ARE ON** the launching ramp*

Case #1. If a boarding float and gangway are located **OFF** of a launching ramp such that the accessible route is not actually **ON** the launching ramp, the accessible route serving the gangway and boarding float must comply with all the requirements for accessible routes in the 2010 ADA Standards Chapter 4. In such a case, the exceptions for gangways on accessible routes serving boarding floats on boat launching ramps will not apply.

Case #2. If a boarding float and gangway are located **ON** the launching ramp, the accessible route serving the gangway and boarding float shall be permitted to use the three (3) exceptions in the 2010 ADA Standards Section 1003.2.2 (Boarding Piers at Boat Launch Ramps) as summarized below.

D9.1.2 The 2010 ADA Standards requirements for accessible routes serving boarding floats on boat launching ramps are as follows:

Section 1003.2.2 Boarding Piers at Boat Launch Ramps. Accessible routes serving boarding piers at boat launch ramps shall be permitted to use the exceptions in **1003.2.2**.

1003.2.2 Exception 1.

Accessible routes serving boarding piers at boat launch ramps shall be permitted to use **Exceptions 1, 2, 5, 6, 7 and 8** in **1003.2.2**.

Exception 1 above permits the use of six (6) of the eight (8) exceptions in **1003.2.1 Boat Slips** as follows:

- **Exception 1:** gangway replacements, alterations and length;
- **Exception 2:** gangway maximum rise;
- --- 3. ---
- --- 4. ---
- **Exception 5:** gangway landings;
- **Exception 6:** gangway handrail extensions;
- **Exception 7:** gangway cross slope; and
- **Exception 8:** gangway changes in level.

The omitted **Exception 3** addresses relief from a maximum gangway slope of 1:12, provided that the gangway is at least 80 ft in length.

The omitted **Exception 4** addresses relief from a maximum gangway slope of 1:12 provided that the boating facility has fewer than 25 boat slips and the gangway is at least 30 ft in length.

1003.2.2 Exception 2.

Where the total length of a gangway or series of gangways serving as part of a required accessible route is 30 ft minimum, gangways shall not be required to comply with a maximum slope of 1:12 as required by ADA Standards 405.2.

1003.2.2 Exception 3.

Where the accessible route serving a floating boarding pier or skid pier is located within a boat launching ramp, the portion of the accessible route located within the boat launching ramp shall not be required to comply with **2010 ADA Standards Section 405** (ramps).

D9.2 Gangway Minimum Uniform Live Loads (ULL)

***100 #/ft² minimum ULL shall be used for gangway structural design.
50 #/ft² minimum shall be used for ULL transferred to floating docks.***

D9.3 Gangway Minimum Width

D9.3.1 Recommended minimum clear gangway width is 36 inches. Anything less is impractical in consideration of typical gangway pedestrian traffic and transfer of goods, supplies and equipment.

D9.3.2 ***Minimum clear width of a gangway on an accessible route shall be 36 inches clear between handrails on each side of an accessible gangway.***

D9.4 Gangway Railings

D9.4.1 Gangway Guard Rails

D9.4.1.1 Guard Rail Loadings

50 Pounds Per Linear Foot
applied horizontally along centerline of top rail

200 Pounds Live Point Load
applied vertically at any point along length of any horizontal guard railing,
including the top rail and any mid-rails

D9.4.1.2 Minimum Guard Rail Height

42 inches measured perpendicular from deck to top of top rail

9.4.1.3 **Guard rail openings shall not permit the passage of a 4 inch diameter rigid sphere.** This can be accomplished by use of horizontal rails, vertical pickets and/or ornamental components. It is not recommended that solid panels be used as this subjects a gangway to larger crosswind loadings that can result in accelerated wear and/or damage to the gangway hinge assembly, the rollers on the lower end and the deck of the boarding float.

D9.4.2 Gangway Handrails

D9.4.2.1 **Handrails shall be provided on both sides of gangways.**

D9.4.2.2 Handrail Heights

Measured perpendicular from gangway deck to top of handrails.

Minimum Gangway Handrail Height:

34 inches

Maximum Gangway Handrail Heights:

38 inches

36 inches on gangways not exceeding a 3:1 slope

35¼ inches on gangways not exceeding a 2½ :1 slope

See the above data highlighted in **Table D9.4.2.2** below.

Table D9.4.2.2

| Perpendicular Height from Top of Handrail to Gangway Deck | | | | | | | | | | |
|--|---|------|------|--------------|-----------------|-----------------|-----------------|-----------------|-----------------|-----------------|
| Slope [H to V] ▼ | 34.0 | 34.5 | 35.0 | 35.25 | 35.5 | 36.0 | 36.5 | 37.0 | 37.5 | 38.0 |
| | Vertical Height from Top of Handrail to Gangway Deck | | | | | | | | | |
| 3:1 | 35.8 | 36.4 | 36.9 | 37.2 | 37.4 | 37.9 | 38.5 | 39.0 | 39.5 | 40.1 |
| 2½ :1 | 36.6 | 37.2 | 37.7 | 38.0 | 38.2 | 38.8 | 39.3 | 39.9 | 40.4 | 40.9 |

D9.5 Gangway Decking

D9.5.1 Gangway decks must have a durable non-skid surface to provide traction, especially when wet, and when gangways are at steeper slopes.

D9.5.2 The use of treads on gangway decks to improve traction is generally to be avoided. However, where gangways remain at steep slopes for long periods, gangway treads may be deemed necessary to develop improved traction.

D9.5.2.1 Gangway treads should meet the following criteria:

- be attached perpendicular to the long axis of the gangway;
- spaced on 12 to 16 inch centers;
- maximum tread width of 1 inch;
- maximum tread height of 1/2 inch; and
- on treads over 1/4 inch, all edges above 1/4 inch beveled at 45 degrees
- See D8.3.2.4 for gangway treads details (similar to gangplank tread details).

D9.5.2.2 ***Gangway treads shall not be used on accessible gangways.***

D9.6 Maximum Gangway Slopes

D9.6.1 On Coastal Waterways:

- 3:1 maximum slope @ 0.0 MLLW or above
- 2 ½:1 maximum slope below 0.0 MLLW

D9.6.2 On Inland Waterways:

- 3:1 maximum slope not less than 90% of the time
- 2 ½:1 maximum slope not more than 10% of the time

D9.6.3 Accessible Gangways on both Coastal and Inland Waterways:

- 1:12 maximum slope

NOTE: The following **Exception 2** (from ADA Standards 1003.2.2) applies to gangways located on accessible routes serving boarding floats on a boat launching ramp.

Exception 2.

Where the total length of the gangway or series of gangways serving as part of a required accessible route is 30 ft minimum, gangways shall not be required to comply with 405.2 (maximum slope of 1:12).

D9.7 Gangplanks provided at the lower and/or upper ends of a gangway provide a smooth transition between the gangway deck surface and shore. The maximum gangplank slope is 3:1 under any in-service conditions or water levels. This applies to gangway gangplanks on both coastal and inland waterways.

D9.8 ***Transition plates are uniquely connected to gangways on accessible routes, and shall not exceed a slope of 1:12 under any and all conditions.***

D9.9 Boarding Floats and Gangway Landings

D9.9.1 Where a boarding float and gangway form an “L” or “T” shape, the float and gangway combination creates a 90 degree intersection. Such an arrangement has two different applications as follows.

D9.9.1.1 ***Where a boarding float/gangway intersection is on an accessible route, a minimum clear width of 60 inches shall be provided between the edge of the gangway transition plate and the far edge of the boarding float.*** This will provide adequate turning space for safely making 90 degrees turns on the surface of an accessible boarding float in preparation for getting off of, or on to, an accessible gangway via a transition plate. 

D9.9.1.2 Where a boarding float and a gangway are not on an accessible route, it is recommended that a minimum clear width of 48 inches be provided between the edge of the gangway transition plate and the far edge of the boarding float. 

D9.10 Accessible Gangways

D9.10.1 An accessible gangway is an element of an accessible route that links floating docks with walkways, piers, bulkheads, parking areas, buildings, and other accessible marina service and activity centers.

D9.10.2 Newly designed, or newly constructed and altered recreational boating facilities, including gangways, are required to comply with federal, state and local governmental authorities. Accessibility requirements apply to each newly designed or newly constructed recreational boating facility.

D9.10.3 Altered recreational boating facilities must conform to federal and state accessibility requirements.

An “alteration” consists of any change in a primary function that adds new services or features. A courtesy dock at a boat launching ramp is not likely to have many services or features other than the basic function of facilitating launching and retrieving of trailer boats, and temporary boat tie-up while towing vehicles are retrieved from parking areas. However, in some cases a courtesy dock may be equipped with lighting, potable water, and/or a boat pumpout station. Routine maintenance work such as the replacement of decking and other dock components does not constitute an alteration.

D9.10.4 Existing boat launching facilities not being altered are not affected by accessibility requirements and rules for recreational boating facilities.

D9.10.5 Where an existing gangway (or a series of gangways that constitutes a single gangway system) is replaced or altered, an increase in the length of the gangway(s) is not required unless alterations are made to an area containing a primary recreational boating function. Here again, this is an element in accessibility guidelines and regulations that applies to marinas but probably will not have any application to a boat launching facility boarding float. However, if an existing boarding float served by a gangway is lengthened, widened or otherwise altered to provide some new significant service or activity, the existing gangway would have to be modified as required to fully meet accessible gangway requirements for length, width and maximum slope.

D9.10.6 Where there is a change in a primary function, and the cost of lengthening an existing gangway is considered to be disproportionate to the cost of the primary function alterations, the gangway does not have to be lengthened. U.S. Department of Justice regulations deem the cost of lengthening a gangway to be disproportionate when the cost exceeds 20% of the cost of the primary function alterations.

+++++

As of March 12, 2012, all types of facilities are now subject to the **2010 ADA Standards**, and are enforced by the U.S. Department of Justice. The **2010 ADA Standards** are applicable to state and local governments, public accommodations and commercial facilities.

+++++

The **California Building Code (CBC)** is updated every three years. On January 1, 2020, the **2019** edition of the **CBC** took effect. Included is **Section 11B-1003 Recreational Boating Facilities**. With regard to Recreational Boating Facilities, the code numbers, titles, text and exceptions are verbatim from the **2010 ADA Standards, Section 1003**. This will greatly facilitate application of the federal and state requirements. In the **2019 CBC** the recreational boating facilities requirements are in Section 11B-208. Parking space requirements are in Section 11B-208.

+++++

Section E: Shoreside Facilities

E1. PARKING FACILITIES

E1.1 Types of Boat Launching Facilities Parking Spaces

E1.1.1 A boat launching facility will commonly have a mixture of several of the following types of vehicle parking spaces:

Vehicle/Trailer Parking Spaces

- single vehicle/trailer spaces
- extra-long single vehicle/trailer spaces
- single recreational vehicle/trailer spaces

Vehicle Parking Spaces

- single vehicle spaces
- compact single vehicle spaces
- extra-long single vehicle spaces
- recreational vehicle spaces
- unhitched trailer parking spaces

Accessible Vehicle/Trailer Parking Spaces

- accessible single vehicle/trailer spaces
- accessible duplex vehicle/trailer spaces
- single van-accessible/trailer spaces
- duplex van-accessible/trailer spaces
- accessible single recreational vehicle/trailer spaces
- accessible duplex recreational vehicle/trailer spaces

Accessible Vehicle Parking Spaces

- accessible single vehicle spaces
- accessible duplex vehicle spaces
- single van-accessible spaces
- duplex van-accessible spaces
- accessible single recreational vehicle spaces
- accessible duplex recreational vehicle spaces

E1.1.2 To the maximum extent possible, vehicle/trailer parking spaces should be provided rather than single vehicle spaces. However, some boat launching facilities are used by boaters who boat in small portable “car-top” light-weight fishing boats, canoes and kayaks that usually do not require trailers. The mix of single vehicle spaces and vehicle-trailer spaces should reflect site-specific parking needs.



vehicle-trailer parking spaces

E1.1.3 Where land area is severely limited or unusual in shape, single vehicle or single trailer spaces for unhitched trailers, or a designated trailer-only parking area may be useful in meeting part of the demand for parking.



single vehicle parking spaces

E1.1.4 Pull-through vehicle/trailer parking spaces are strongly recommended and should be utilized to the maximum extent possible. Pull-through parking spaces eliminate backing, a problem for many boaters who are not proficient in backing their vehicles with a trailer attached, especially when parking areas are busy.



pull-through V/T parking spaces

E1.1.5 A nominal number of single vehicle parking spaces can and should be provided in small irregular shaped areas not large enough for vehicle/trailer spaces. They can also be provided at the ends of rows of diagonal vehicle/trailer parking spaces served by two-way traffic driveways on each side of the diagonal parking. The provision of a few vehicle-only spaces will help to address the parking capacity problem sometimes caused by single vehicles parked in vehicle/trailer spaces.



end of row single parking space

E1.1.6 At certain sites there may be a demonstrated demand for recreational vehicle/trailer parking spaces longer than the standard 40 ft vehicle/trailer parking space (see E1.4.1).



unmarked RV parking spaces

E1.1.7 It is important to prevent non-boater parking in parking spaces specifically intended for the parking of vehicles and trailers utilized in launching and retrieving recreational boats.



large visual expanse of AC paving

E1.1.8 Large visual expanses of asphalt paving are to be avoided through the use of appropriately placed planter islands and planter strips. These planter areas should also be used as a primary means of directing and controlling traffic flow and drainage. Small areas suitable for landscaping are typically available at the ends of rows of parking.

E1.2 Location of Parking Spaces

Where physically possible to do so, all parking spaces should be within 600 ft of the boat launching ramp, but without encroaching into the maneuvering apron at the head of a launching ramp.

E1.3 Minimum Number of Parking Spaces

E1.3.1 The typical minimum parking space ratio is 20 to 30 vehicle/trailer parking spaces per launching lane. The parking demand will vary with the type of waterbody, boating activities allowed, and the nature of the site, i.e., urban, rural, coastal, inland, high altitude, desert, etc.

E1.3.2 There should be a sufficient number of each type of parking space provided to meet the expected demand on a normal peak day during the boating season. Using a summer weekend holiday to establish parking demand will probably result in a facility that is overbuilt and too large for the normal daily and weekly demands during the season. It not only wastes project construction funding and land use, but maintenance funds as well.

E1.4 Minimum Parking Space Dimensions

E1.4.1 Vehicle/Trailer Parking Spaces

Minimum Length: 40 ft
Minimum Width: 10 ft

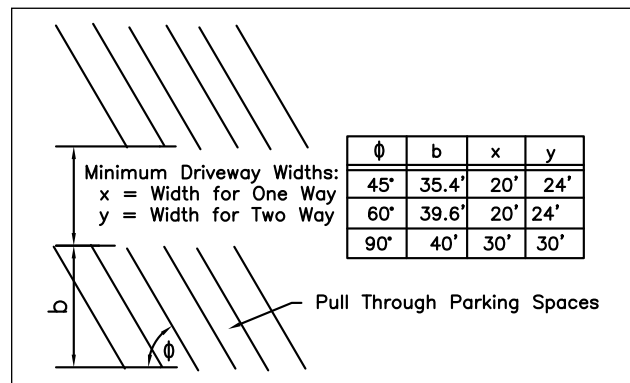

typical vehicle/trailer parking space layout

E1.4.2 Single Vehicle Parking Spaces



Minimum Length: 20 ft
Minimum Width: 9 ft

E1.4.2.1 Compact vehicle parking spaces can be provided by reducing single vehicle spaces down to 8 ft wide and 18 ft long if space is limited. Each compact parking space should be identified with a 12 inch high white “C” (for “Compact”) painted on the centerline of the parking space entrance.

E1.4.3 Van Parking Spaces

Van parking spaces are not normally delineated in a public parking area. However, van-accessible parking spaces are legally required, and have very specific dimensions, pavement markings, and sign requirements. For van-accessible parking space requirements, see E2.3.2 Accessible Parking Space Table.

E1.4.4 Recreational Vehicle/Trailer Parking Spaces

Minimum Length: 40 ft
Minimum Width: 12 ft

E1.4.5 Recreational Vehicle Parking Spaces (RV)

Minimum Length: 20 ft
Minimum Width: 12 ft

E1.4.6 Extra-Long Vehicle/Trailer Parking Spaces; and Extra-Long RV / Trailer Parking Spaces

Length Range: 40 to 65 ft
Trailer Length Range: up to 25 ft
Minimum Width: 12 ft

NOTE:

In California, a passenger vehicle towing a trailer cannot exceed an overall length of 65 ft.

E1.4.7 Extra-Long Recreational Vehicle Parking Space



Length Range: 20 to 40 ft
Trailer Length Range: up to 25 ft
Minimum Width: 12 ft

E1.5 Parking Lot Finish Grades

- 1% minimum slope
- 2% recommended minimum slope
- 5% recommended maximum slope
- 10% maximum slope.

E2. ACCESSIBLE PARKING SPACES (Barrier-Free Parking)

E2.1 General Requirements

E2.1.1 ***Boat launching facility parking shall include accessible parking.***

E2.1.2 Accessible parking spaces should be located on the shortest accessible route between the accessible parking spaces and the boat launching ramp, restrooms and any other significant facility features or areas of activity.

However, the shortest accessible route is not always the best and safest route. For example, a number of boat launching ramps have been constructed on high elevation lakes and reservoirs. The slopes above and below the high waterline are frequently great challenges. Efforts to provide the shortest accessible routes can solve one problem, and create other problems. Accessibility, safety, exorbitant construction costs and maintenance expenses have to be considered and addressed concurrently.

Note: For information on accessible parking spaces, refer to:

- **2010 ADA Standards** --- Section 208 Parking Spaces, and Section 216.5 Parking Signs; and
- **2013 California Building Code (CBC)** --- (effective January 1, 2014) Sections: 11B-208 Parking Spaces, and 11B-502 Parking Spaces.

E2.1.3 ***Ramps shall not encroach into any accessible parking spaces, or accessible aisles adjacent to accessible parking spaces.***

E2.1.4 ***Accessible parking spaces and access aisles shall not have slopes in any direction in excess of 2%.***

E2.1.5 ***With the exception of pull-through accessible parking spaces, each accessible parking space shall be provided with wheel stops (bumpers), or curbs, to prevent encroachment of***



accessible ramp and access aisle

vehicles into accessible routes in front of the accessible parking spaces.

E2.1.6 Accessible parking spaces should be located such that persons with disabilities are not compelled to wheel or walk behind parked vehicles other than their own.



parking space wheelstop

E2.1.7 **Accessible parking spaces shall be reserved for use by persons with disabilities who have legal placards on their vehicle windshields or stickers on the vehicle license plates.**

Note: See the exception to this requirement in E2.2.4.1 for parking lots with less than five (5) parking spaces.

E2.2 Minimum Number of Accessible Parking Spaces

E2.2.1 Table E2.2.1 presents the minimum number of required accessible parking spaces. The total number of spaces in the left column includes all types of parking spaces. For the various types of boat launching facility parking spaces, see E1.1. For parking lots with less than five parking spaces, see E2.2.4.

E2.2.2 **Each boat launching facility parking lot shall provide a minimum of one (1) accessible parking space for each type of parking space provided in the parking lot.** For the various types of boat launching facility parking spaces, see E1.1.

E2.2.3 **For every six or fraction of six accessible parking spaces, at least one shall be van-accessible, and meet all minimum size, access aisle, sign and pavement marking requirements.**

➔ **Example: a 210 space parking lot must have seven (7) accessible parking spaces, two (2) of which must be van-accessible.**

E2.2.4 Parking Lots With Less Than Five (5) Parking Spaces

E2.2.4.1 **Where a boat launching facility has less than five (5) parking**

| Total Number of Parking Spaces | Minimum Number of Required Accessible Spaces |
|---------------------------------------|---|
| 1-25 | 1 |
| 26-50 | 2 |
| 51-75 | 3 |
| 76-100 | 4 |
| 101-150 | 5 |
| 151-200 | 6 |
| 201-300 | 7 |
| 301-400 | 8 |
| 401-500 | 9 |
| 501-1,000 | 2% of total |
| 1,001 and over | 20+1 for each 100, or fraction over 1,001 |



spaces, one (1) van accessible aisle shall be provided on passenger side of the parking space. However, there is no requirement that the van-accessible parking space be identified as van-accessible, or be identified and reserved for exclusive use by persons with disabilities. No signs or pavement markings are required to identify a van-accessible parking space or adjoining access aisle. In such small parking areas, reserving one accessible parking space and an access aisle would result in at least 25% of the parking spaces being reserved. This would be far out of balance with Table E2.2.1.



parking space markings. note accessible aisle border should be blue color

E2.2.4.2 A van-accessible parking space and access aisle shall meet the same minimum length, width and maximum cross slope dimensions that are required in larger parking lots.

E2.3 Minimum Dimensions and Layout Factors (See Table E2.3)

E2.3.1 General Criteria Applied to Boat Launching Facility Parking Spaces

E2.3.1.1 Both federal and state accessibility requirements specify that **single vehicle accessible parking spaces shall be not less than 8 ft (96 in) in width.** However, at boat launching facilities it is necessary and prudent to provide wider parking spaces in consideration of the typical vehicle-trailer traffic that will be present, and the loading and unloading of people and gear that is normal.



10 ft wide vehicle-trailer spaces



9 ft wide vehicle-only spaces

Therefore, in these GUIDELINES, single vehicle parking spaces will be addressed as not less than 9 ft in width (exceptions noted in context), and vehicle/trailer spaces not less than 10 ft in width.

E2.3.1.2 The width of accessible parking space stripes should be 4 inches, painted white in color with paint specifically manufactured for pavement

E2.3 Table of Accessibility Parking Space Dimensions and Layout Details

| Parking Space Type | Parking Space and Access Aisle Widths (ft) | | | Parking Space Length (ft) | Location of Access Aisles | |
|-------------------------------------|--|--------------------|---------------|---------------------------|--|---|
| | Parking Space(s) Width | Access Aisle Width | Overall Width | | Two-Way Pull-Thru Traffic | One-Way Pull-Thru, and Pull-In, Back-Out Traffic |
| Vehicle/Trailer Single Space | 10 | 5 | 15 | 40 | <p><i>The access aisle may be provided on either side of a pull-thru parking space where it can be entered and exited from either end.</i></p> | <p><i>The access aisle shall be located on the passenger side of the vehicle where accessible parking spaces are:</i></p> <p>A-- subject to only one-way traffic;</p> <p>and</p> <p>B-- subject to diagonal pull-in and back-out parking spaces.</p> |
| Vehicle Single Space | 9 | 5 | 14 | 20 | | |
| Vehicle/Trailer Duplex Space | 2 @ 10 | 5 | 25 | 40 | | |
| Vehicle Duplex Space | 2 @ 9 | 5 | 23 | 20 | | |
| Van/Trailer Single Space | 11 | 5 | 16 | 40 | | |
| Van Single Space | 11 | 5 | 16 | 20 | | |
| Van/Trailer Duplex Space | 2 @ 11 | 5 | 27 | 40 | | |
| Exception: | 2 @ 8 | 8 | 24 | 40 | | |
| Van Duplex Space | 2 @ 11 | 5 | 27 | 20 | | |
| Exception: | 2 @ 8 | 8 | 24 | 20 | | |
| RV/Trailer Single Space | 11 | 5 | 16 | 60 | | |
| RV/Trailer Extra Long Single Space | 11 | 5 | 16 | not to exceed 65 ft | | |
| RV Single Space | 11 | 5 | 16 | 40 | | |
| RV/Trailer Duplex Space | 2 @ 11 | 5 | 27 | 60 | | |
| RV/Trailer Extra Long Duplex Space | 2 @ 11 | 5 | 27 | not to exceed 65 ft | | |
| RV Duplex Space | 2 @ 11 | 5 | 27 | 40 | | |



striping. Other colors can be used but white is recommended because it is usually more visible under a variety of light and weather conditions. Check with local permitting authorities for verification of paint stripe requirements.

E2.3.1.3 When laying out and painting parking lot stripes, measurements may be made to the centerline of stripes between adjacent parking spaces. For example, a 12 parking space row of 9 ft wide 90 degrees single vehicle parking spaces will have a nominal overall width of 108 ft. Each 4-inch wide parking stripe will overlay two adjacent parking spaces, 2 inches on each side of the stripe centerline.



measure to center of painted stripes

E2.3.1.4 Where an individual parking space is defined by a raised curb on one side and a paint stripe on the other, the parking space width is to be measured from the face of the curb to the centerline of the paint stripe.

E2.3.1.5 Where an individual parking space is defined by raised curbs on both sides, the parking space width is to be measured between curb faces. Sometimes paint stripes are also provided within the raised curbs.

E2.3.2 Accessible recreational vehicle (RV) parking spaces, with or without trailers, should be provided where verified local demand and use exists. Such spaces are large, and have an impact on the overall layout of a parking facility including extra width, length, turning radii, and driveway widths between rows of parking spaces. Accessible RV parking spaces are not specifically addressed in federal and state accessibility requirements for boat launching facilities, but they will be similar in nature to van-accessible parking spaces, and are covered as such in these GUIDELINES.



E2.4 Access Aisles

E2.4.1 ***Access aisles shall adjoin an accessible route.***

E2.4.1.1 In parking facilities where the accessible route must cross vehicular traffic lanes, marked crossings enhance pedestrian safety, particularly for people using wheelchairs, walkers and/or other mobility aids.



E2.4.1.2 Where possible to avoid it, it is preferable that accessible routes do not pass behind parked vehicles.

E2.4.2 ***Access aisles shall be permitted to be placed on either side of the***

parking space except for angled van-accessible parking spaces which shall have access aisles located on the passenger side of the parking spaces.

E2.4.3 Two (2) accessible parking spaces shall be permitted to share a common access aisle.



parking space and access aisle



spaces with shared access aisle

E2.4.4 The width of an access aisle shall be not less than either of the two following options:

- **60 inches (5 ft) minimum when adjacent to a 132 inch (11 ft) wide van-accessible parking space;** or
- **96 inches (8 ft) minimum when adjacent to a 96 inch (8 ft) wide van-accessible parking space.**

E2.4.4.1 Where an access aisle serves duplex pull-through van-accessible parking spaces (**VAPS**), only the following three width combinations may be used.

Basic Width Requirements:

two (2) 11 ft wide VAPS + one (1) 5 ft wide access aisle = 27 ft total.

Exception:

two (2) 8 ft wide VAPS + one (1) 8 ft wide access aisle = 24 ft total.

Option:

two (2) 11 ft wide VAPS + one (1) 8 ft wide access aisle = 30 ft total.

The **Exception** above is the most efficient from a land use viewpoint, and fully meets accessibility requirements. However, keep in mind that it is illegal to park a vehicle in an access aisle, even if the driver and/or a passenger(s) possesses proof of disability, and even if the vehicle has a placard on the windshield and/or stickers on the rear license plate. Therefore, access aisles must be outlined, cross-hatched and marked “**NO PARKING.**” It will be necessary to park far-left or far-right within the 8 ft width of the parking space, depending on which side of the van a person(s) with a disability exits or enters the van, and which side of the parking space the access aisle is on.

The **Option** above (30 ft wide) takes 25% more land area than the **Exception** (24 ft wide). Do not, however, be too quick to discount the value of this option. 11 ft wide parking spaces are wide enough for an 8 ft wide van to park far to the left or far to the right, depending on whether a person with a disability must exit the van on the left as a driver, or on the right as a passenger. And, sometimes drivers must use a right-side exit door, and in some vehicles passengers have to use left-side exit doors as well. The 11 ft wide parking spaces are very accommodating and easy to drive into and out of. And the option is available to provide a 5 ft or an 8 ft wide access aisle, depending on how cramped for space a given parking facility is.

The above **Option** is probably overkill. But it is an option that may have merit at particular sites. Negatively, it may lead to illegal parking in access aisles.

E2.4.5 Access aisles shall extend the full length of the parking spaces they serve.

E2.4.6 Access aisles shall not extend into vehicular ways, including driveways and roadways.

E2.4.7 Access aisles shall be clearly defined with painted continuous borders and cross-hatched diagonal lines at 45 degrees on 36 inch centers within the borders. The 2010 ADA Standards do not specify the method, width or color of access aisles. But the California Building Code (CBC) requires blue access aisle borders, and diagonal lines of a contrasting color (compared to pavement color), preferably blue or white. Borders and lines are typically 4 inches wide.



45 degree diagonal lines on 3 ft centers plus "NO PARKING" notification

E2.4.8 Each access aisle shall have a "NO PARKING" notification painted in white letters, not less than 12 inches high, on the access aisle pavement surface at the entrance end of the parking space.

This notification requirement applies to 5 ft wide access aisles for individual and duplex parking spaces of various types, as well as to 8 ft wide access aisles for van-accessible and recreational vehicle accessible parking spaces.

E2.4.8.1 The pavement notification shall be located within the boundary of access aisles and located such that the painted words are visible to law enforcement officials even if vehicles are illegally parked in the access aisles.

E2.4.8.2 The continuous diagonal cross-hatch lines across each access aisle shall be interrupted when passing through the pavement notification, stopping and starting approximately 4 inches clear all around the notification to provide a frame to enhance legibility. The “**NO PARKING**” notification is not to be painted parallel to the diagonal cross-hatch lines, but squared up with the sides of the access aisle.

E2.4.8.3 Where vehicles can enter accessible parking spaces from either end (two-way traffic pattern), the access aisles shall have “NO PARKING” notifications at both ends.

E2.5 Parking Space Signs and Pavement Markings

E2.5.1 Each accessible parking space is “reserved” for use by persons with disabilities, and shall be identified by signs.

E2.5.1.1 Each accessible parking space shall be identified with a symbol of accessibility sign meeting the requirements for design, color, size and location under one of the two following options:

Sign Option 1:

- reflectorized sign of durable metal or plastic material;
- sign area not less than 70 square inches;
- International Symbol of Accessibility (white logo wheelchair image with occupant on dark blue background);
- permanently mounted on centerline post;
- located at interior end of parking space;
- minimum height of 80 inches, measured bottom of sign to pavement;
- separate sign reading “**Minimum Fine \$250**” mounted below the logo accessibility sign.

Sign Option 2:

- same as Option 1, with modifications;
- sign permanently mounted on wall in front of parking space;
- 36 inch minimum height measured from pavement to bottom of sign.

E2.5.1.2 Each van-accessible parking space shall have a sign reading “Van Accessible.” It may be provided on the 70 inch sign below the logo in Option 1 above, or on a separate sign immediately below the logo sign. In either case, the 36 inch minimum height from pavement will apply.

E2.5.2 An accessibility information and notification sign shall be posted in a conspicuous place at each entrance to a parking facility, or immediately adjacent to and visible from each accessible parking space.

This sign(s) is in addition to the signs required in E2.5.1.1.

E2.5.2.1 *The information and notification sign shall have:*

- dimensions not less than 17 inches by 22 inches in size;
- lettering not less than 1 inch in height;
- blank spaces filled in with appropriate information, and updated as necessary, as a permanent part of the sign; and
- clear and conspicuous text stating the following:



van-accessible parking sign



E2.5.3 *In addition to the sign requirements, each accessible parking space shall have permanent pavement identification markings.*

E2.5.3.1 *The parking space markings shall be as per one of the two following options:*

Pavement Marking Option 1.

- outlining or painting the parking space in blue;
- white profile image of a wheelchair with occupant, or other suitable contrasting color.



accessible parking symbol

Pavement Marking Option 2.

- white profile image of a wheelchair with occupant;
- on dark blue background;
- located in center of parking space at entrance end;
- overall image 36 inches high by 36 inches wide.

E2.5.3.2 All “white on blue” accessible profile images shall be located at the entrance end of accessible parking spaces, and be clearly visible to law enforcement officers when a vehicle is properly parked.

E2.5.3.3 Signs and pavement markings for accessible pull-through parking spaces with two-way traffic patterns shall be provided at both ends of the parking spaces.

E2.5.3.4 Signs for accessible pull-through parking spaces obviously cannot be located on posts or walls within or at the ends of the parking spaces. Therefore, pull-through spaces have to be signed as per E2.5.1.1, Option 1, with the sign posts located within the access aisles adjacent to the parking spaces.



access aisles with sets of signs

E2.5.3.5 Sign posts in access aisles shall be offset to one side at least 36 inches clear to centerline of access aisle border so as not to be:

- barriers on accessible routes along access aisles; or
- obstructions to vehicles entering or exiting parking spaces; or
- obstructions to opening and closing parked vehicle doors.

E2.5.3.6 In accessible duplex parking spaces (two parking spaces separated by a common access aisle), accessibility sign posts and signs shall be provided for both parking spaces. The posts and signs shall be positioned such that the overhead clearance along the accessible route is not less than 98 inches (8 ft-2 inch) clear.

E3. ROADWAYS AND PARKING AREAS

E3.1 Access Roads

E3.1.1 Access roads to and from boat launching facilities include city streets, county roads, and state highways. Viewed from the landside, a boat launching facility is essentially a destination point for people and their vehicles via some type of access road. Therefore, boat launching facilities must be designed, constructed and operated in harmony with access roads and the vehicle traffic they carry.

E3.1.2 Each boat launching facility should be identified with appropriate signs located on the access road at locations dictated by site conditions. Some access roads end at the boat launching facility, while others pass along side the facility, providing access from two directions. The presence of access road curves, corners, intersections, and sight-distance obstructions such as hills, buildings and trees must be considered in the placement of signs.



boat launching facility sign

E3.1.3 Designers of boat launching facilities must work with local and state highway officials to determine if right and/or left turning lanes are required on access roads that provide access to and from a boat launching facility.

E3.1.4 Specific attention must be given to how an access road aligns with the internal driveways of a boat launching facility. A well designed facility will be simple in its layout, provide safe and comfortable turns and curves easily negotiated by vehicles pulling boat trailers, and clearly signed to identify the location of the boat ramp, parking areas, restrooms and any potential problems.

E3.1.4.1 Potential problems could be any number of things specific to a particular boat launching facility. Examples are overhead powerlines, potential periodic flooding of river-based launching ramps, industrial or agricultural activities on adjoining lands, waterbody factors such as river velocities and currents, and the presence of large agricultural implements seasonally moved along access roads.

E3.1.4.2 In cases where an access road dead ends at a boat launching facility, the alignment of the access road, internal driveways and boat launching ramp should be offset and/or angled if possible to do so. This can be done with dog-legs, turns and corners. A straight alignment of these access elements may inadvertently lead to an attractive nuisance or an unsafe facility.

- Some bicyclists may be tempted to jump their bikes into the water from overhanging cliffs, piers and boat ramps, especially during high-water periods. This can occur at lake, river and coastal based boat launching facilities alike. The provision of a “straight shot” or uninterrupted path that would allow a bike rider to gather speed through a boat launching facility in preparation for jumping a bike into the water should be avoided. One simple solution is to provide “biker bumps” (similar to vehicle speed bumps) and “bump ahead” warning signs at appropriate locations leading to a boat launching ramp and boarding floats.



entrance road in on the right--boat ramp ahead at center--exit road out on the left



bike jumper on boat ramp float

- Additionally, the interruption of the alignment will help guard against the inadvertent and accidental driving of a vehicle down a launching ramp and into a waterbody. A driver may be lost, disoriented by darkness or bright sunlight, severe weather conditions, intoxicated, etc., and drive into the water thinking they are still driving on an access road.



boat launching ramp with safety warning signs: at end of access road, and at top of launching ramp

E3.1.4.3 If site conditions or the configuration of the property do not allow for the interruption of the roadway alignments, various safety and warning devices must be provided. The careful use and maintenance of flashing amber lights, area lighting, reflectorized warning signs, speed bumps, gates, entrance kiosks, traffic circles or other appropriate means must be utilized to enhance the safe use of a boat launching facility.

E3.2 Parking Lot Driveways

E3.2.1 Minimum driveway widths between rows of parking spaces:



- 20 ft for one-way traffic driveways -- serving 45 degree and 60 degree parking spaces;
- 24 ft for two-way traffic driveways -- serving 45 degree and 60 degree parking spaces;
- 30 ft for one-way and two-way traffic driveways – serving 90 degree parking spaces.



two-way driveway for 60 degree parking

E3.2.2 A maximum cross slope of 3% is recommended for parking lot driveways. A cross slope greater than 3% may influence some vehicles to begin to “veer” right or left in the downward direction of the cross slope. Many driveways carry two-way traffic, most of which will be vehicles pulling boat trailers. Therefore, any design criteria that will enhance safe passage through a boat launching facility parking lot is recommended.



two-way driveway for 90 degree parking

E3.3 Parking Lot Pavement Design Considerations

E3.3.1 Parking lots for boat launching facilities are typically paved with asphalt concrete (AC). However, concrete pavement is typically required by permitting agencies for parking lots that are below the high water elevation. Concrete pavement is also recommended for accessible parking spaces and aisles due to greater degree of control of grade and slope to ensure requirements for accessibility are met long term.

E3.3.2 Absent any specific local agency permit requirements for AC paving, it is recommended that a minimum 2 inch layer of AC paving be provided over a minimum 6 inch compacted rock base. Unless local soil conditions are extremely poor such as on peat or unconsolidated fill, “2 on 6” works well on boat launching facility parking lots if they are properly maintained over the service life of the facility. They do not have to be designed and built to highway standards, but do have to be sturdy enough to withstand the grinding action of tires when vehicles enter and exit parking spaces. This seems to be a particular problem when vehicle wheels are turned on hot pavement while the vehicle is not in motion.

E3.3.3 Special specifications may be necessary for parking pavement in unusually hot or cold climates in desert and mountain regions. Check with district offices of the California Department of Transportation for recommendations.

E3.3.4 It is not recommended that a fog seal be applied to new paving until it is approximately one year old. New paving is still somewhat pliable and will continue to compact under traffic loads the first few months following construction. A fog seal applied too soon will quickly break down as the pavement stabilizes over the first year, and will be an ineffective and wasteful expenditure of construction funds.

E3.3.5 Asphalt curbing is economical and serves well for drainage control. However, it is to be avoided where vehicle wheels will impact and/or come to rest against asphalt curbs. Wheels will impact and break the curbs, particularly during warm summer months when prolonged heat softens the asphalt. Where wheel loads occur against curbing, concrete curbs or wheel stops should be used.

E3.4 Unpaved Parking

E3.4.1 Unpaved parking areas are sometimes provided at small boat launching facilities in remote locations with low levels of use, and at sites with particular soil or environmental problems that preclude the use of AC paving. In such cases, gravel and other durable compactable rock products can be utilized as required. Otherwise, during wet weather an unpaved parking area may be totally unusable depending on the soil conditions, drainage, and the weight and types of vehicles and boat trailers being parked.



E4. RESTROOM FACILITIES

E4.1 General Requirements

E4.1.1 Minimum restroom requirements:

- one (1) unisex restroom for 20 parking spaces, or fraction thereof; or
- one (1) toilet fixture per sex, and one (1) urinal in men's room for each 30 parking spaces, or fraction thereof;
- the total number of parking spaces includes all of the various types of parking spaces provided, including accessible parking spaces.



restroom at boat launching facility

E4.1.2 Providing unisex restrooms should be considered at boat launching facilities. When we consider the number of people who bring their young children to go boating from boat launching ramps, we see and appreciate the obvious need to provide unisex restrooms. A mother can take her very young son and help him use the toilet in a unisex restroom without causing modesty problems. Likewise, the dad can do the same for his young daughter as needed.

Additionally, paralyzed military veterans often desire to go boating with friends, but they frequently need some level of assistance from their wives, husbands or companions to use the restrooms. Unisex restrooms solve a lot of problems.

E4.1.2 Restrooms should be located near and convenient to the launching ramp, with due consideration of traffic patterns and accessible routes between the restrooms, launching ramp and accessible parking spaces.

E4.1.3 Restroom architectural design should be compatible with the surrounding area and existing structures.

E4.1.4 To the extent possible, restroom buildings are to be constructed of vandal resistant, low maintenance, fire resistant materials. Consideration should be given to the following:

- polished chrome plated mirrors in lieu of glass mirrors;
- durable coated steel doors and door frames;
- solid polyethylene toilet partitions;
- reinforced concrete foundation slabs;
- good ventilation;
- insect window and ventilation opening screening;
- urine resistant wall coatings (tile, epoxy, etc.);
- fire resistant roofing; and
- stainless steel or aluminum toilet fixtures.

E4.2 Public Health and Accessibility Requirements

E4.2.1 Restrooms must meet all federal, state and local public health requirements and guidelines, as well as federal and state requirements for accessibility.

E4.2.2 Trash receptacles should be provided near the launching ramp, restrooms, and elsewhere as required and necessary.

E4.2.3 If shower facilities are necessary, they should generally be exterior open public “cold water showers” consisting of a shower head on the outside of the restroom building and a small concrete slab and drainage features.



E5. UTILITIES

E5.1 Potable Water

E5.1.1 Provision of drinking water fountains should be considered if potable water is available. ***Where drinking fountains are provided they shall be accessible by persons with disabilities.***



2-way boat washdown facility

E5.1.2 A fresh water boat and engine washdown area should be provided at boat launching facility projects constructed in salt water areas, and as needed at fresh water projects.

E5.1.2.1 Washdown areas should be located on concrete slabs that are drained and the wash water is directed through storm drain filters for disposal away from the waterbody and the launching ramp.

E5.1.2.1 A washdown area may have to be monitored, coin operated or otherwise controlled for water conservation. If not, the washdown facility will possibly be used as a free public vehicle and boat wash facility, particularly during periods of drought when water use may be locally restricted.

E5.1.2.2 Unless protective enclosed hose reels are provided, hoses should not be provided as they will probably be vandalized or stolen. If durable hose bibs are provided, boaters will learn to bring their own hoses and engine fittings as required to wash their engines, boats and trailers.

E5.2 Oil Recovery and Sewer Systems

E5.2.1 If drainage and sewer systems include an oil recovery feature, the entire system will need to be monitored, serviced and maintained on a regular basis. Periodically, as use dictates, the recovered oil must be disposed of as per applicable water quality requirements.

E5.3 Area Lighting

E5.3.1 Area lighting is recommended if use and safety conditions warrant.

E5.3.2 Light standards and fixtures should be selected to effectively light the launching ramp, parking and restroom areas, but not be intrusive into adjacent properties.



launch ramp lighting

Night lighting will discourage vandalism and enhance the overall security of the facility.

E5.3.3 Light fixtures should be directed and/or shielded in such a way that they do not blind boat operators returning to the launching ramp at night.

E5.3.4 A light standard and “white-light” fixture approximately 20 to 25 ft high near the head of the launching ramp should be considered for projects where night launching and retrieving of boats occurs. A white light on a standard pole on shore does not violate navigation codes, and serves as a guide to incoming boats for locating the launching ramp at night.

E5.4 Overhead Electrical Powerlines



NO OVERHEAD POWERLINES WILL BE PERMITTED to pass over parking areas, temporary overflow parking areas, launching ramp areas, driveways, approach areas, and/or any other areas where a vehicle can be driven while towing a boat trailer within the boundaries of a boat launching facility, except as modified in the exception below.

EXCEPTION: Overhead powerlines may be permitted if such lines have not less than 48 ft vertical clearance over any vehicle/trailer operating area within a boat launching facility. In the determination of the actual minimum clearance at a specific site, due consideration shall be given to the following factors:

- ***clearance measured at the low point of the line(s);***
- ***elongation and sag of the powerlines over their expected service life;***
- ***thermal expansion and sag of lines on hot summer days;***
- ***“live loads” on the lines from roosting birds and debris; and***
- ***provision of warning signs including overhead clearance.***

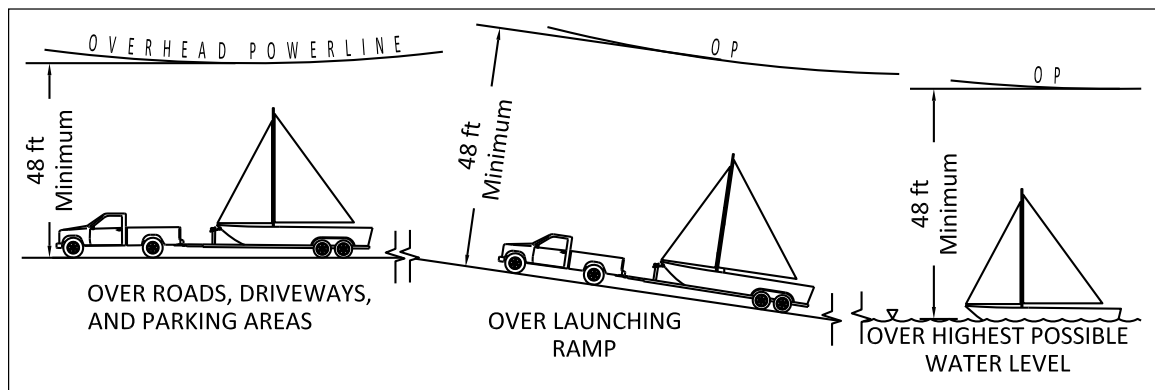

*48 ft minimum powerline clearance
[Does not apply over the waterbody away from the launching ramp.]*

NOTE:

The above overhead powerline prohibition and exception guidelines are included as a safety measure in consideration of the growing number of trailerable sailboats that can be outfitted with conductive metal masts and rigging hardware. In the event that such a sailboat is trailered or sailed under an overhead powerline, a raised conductive metal mast can possibly come into contact with the powerline. Such contact can be very serious, resulting in damage to the mast and sailboat as well as possible severe injury and/or death by electrocution of persons who may be in, on or near the sailboat and its rigging. Such tragedies have occurred in the past and will probably happen again in the future unless steps are taken to educate boaters and avoid the presence of overhead electrical powerlines below a safe minimum vertical clearance. These guidelines are provided to help ensure that such tragedies are avoided in the future.

E6. SIGNS

E6.1 Types of Signs

E6.1.1 The types of signs commonly utilized include:

- project identification signs;
- directional signs;
- information signs; and
- safety signs.

E6.1.1.1 Project identification signs typically include the name of the boat launching facility, the agency responsible for operation and maintenance, and the funding agency(s), i.e., the Harbors and Watercraft Revolving Fund. Project signs are a requirement in all grant agreements with local agencies. Signs often include logos of agencies involved in the funding, operation and maintenance of the facility.



project identification sign being delivered for installation

E6.1.1.2 Directional signs direct (a) incoming vehicle traffic to parking areas, restrooms, launching ramps and other project features and activity centers; (2) as well as directing exiting traffic to boat washdown facilities, trailer boat tie-down areas and exit driveways and roadways.



project information signs

E6.1.1.3 Information signs are typically site specific and inform boaters of particular things related to a boat launching facility. Such signs may include information on special events, local or regional activities, the local waterbody and shoreline, instructions related to aquatic weeds and their transfer to other waterbodies on boats and trailers, emergency phone number(s), and/or rules and regulations including daily and seasonal operational hours, services and prohibited activities.

E6.1.1.4 Safety signs address specific conditions and/or hazards that have been identified and signed at specific boat launching facilities or waterbodies. These conditions and hazards may be temporary, permanent, seasonal, operational or social in nature.

- Temporary situations may include construction activities and the presence of large equipment used in the modification, expansion or repair of various facility components.
- Permanent situations may include the presence of overhead electrical powerlines, water currents in rivers, and tides and sneaker waves at coastal installations.
- Seasonal situations may include exposure of rock outcroppings at low water levels in lakes and reservoirs, or infrequent exposure of abandoned bridge piers or construction debris during extended periods of drought.
- Operational situations may include the operation of gates, spillways or other hydraulic equipment that rapidly influence river, stream and/or lake water levels and currents, as well as wind warning systems at locations where strong wind currents may suddenly arise and warning lights and sirens call for the removal of all boats and boaters from the waterbody. These kinds of things can occur at a boat launching facility on a river or afterbay below a dam, and on



project safety sign



water hazzard warning sign



*potential river safety situation
--- spring break on Colorado River*

lakes in wind swept valleys.

- Social situations may include the extreme influx of college students at local lakes and rivers during Spring Break, the rafting of great numbers of boats on lakes or bays to observe fire works displays on the 4th of July, or some particular boating activity such as “running” rivers during high spring runoff flows.

E6.2 Location, Orientation and Legibility

E6.2.1 Effective signs must clearly communicate the desired information, messages and/or warnings. Therefore, signs must be legible, properly sized, and appropriately located and oriented for maximum visibility and ease of reading. Effective signs will often combine symbols and logos with text to communicate with an economy of words.

E6.2.2 Project identification signs should be located at or near the entrance of a boat launching facility such that they do not block sight lines along access roads or parking lots.

E6.2.3 Directional, information and safety signs must be located and orientated in response to the actual site needs. Care must be taken to ensure that trees and bushes do not grow and obscure sign visibility in the future.

E6.2.4 Sign legibility is influenced by the basic sign design, style, shape, size, colors, color contrast, lettering height, font style, logos used, materials, finish, lighting, craftsmanship and the setting in which the sign is to be located.



water hazard warning sign



concrete project identification sign



wood project identification sign

E6.3 Size of Signs

E6.3.1 Project identification signs are typically 5 to 10 ft in length and up to 4 ft high, depending on the name of the facility, the type of facility and the ownership and funding acknowledgments typically provided on such signs.



E6.3.2 Sign size and design will have a direct bearing on the sign thickness, dead weight and support components such as posts, pedestals and bases.

E6.4 Design Details

E6.4.1 Absent other required local agency specifications, guidelines and standards, the following criteria is recommended for the layout and fabrication of project identification signs for projects funded by the Department of Parks and Recreation, Division of Boating and Waterways.

| Project Identification Sign Design Criteria | | |
|---|--|--|
| Detail Items | Design Criteria | Illustration |
| Sign Panel: Minimum Length Thickness | 5 ft (60 inches) 8 inches |  |
| Sign Base: Length Width Thickness | sign length + 24 inches as required by design 6 inch minimum | |
| Sign Material: Sign and Base | reinforced concrete | |
| Sign Lettering Heights: Project Name Type of Project Credits | 8 inches for upper case 5 inches for lower case 4 inches all upper case 2 inches all upper case 2 inches between lines | <p>Miller Park</p> <p>BOAT LAUNCHING FACILITY</p> <p>Funded by California Department of Parks and Recreation</p> <p>•</p> <p>Division of Boating and Waterways</p> <p>Operated and Maintained by City of Sacramento</p> |
| In general, a minimum 2 inch high letter height is legible at reading distances of 50 ft and less. The letter height should be increased ½ inch in height for every additional 50 ft of reading distance from the sign. | | <p>Miller Park Miller Park Miller Park Miller Park Miller Park</p> |

Appendix A: Commentary

Appendix A is **COMMENTARY** provided to enhance, explain and comment on various aspects of the **GUIDELINES** presented in Sections B through E. The capital letters and numbers at the head of each “**COMMENTARY**” are direct back-references to the material presented in Sections C, D, and E. The intent is to keep the **GUIDELINES** fairly brief, but also provide additional information that can be referred to as needed.

The **COMMENTARY** sections address the following topics:

- Section C. Launching Ramps
- Section D. Boarding Floats
- Section E. Shoreside Facilities

The “Flag” symbol in the right margin beside this paragraph appears in the right margins at various places throughout Sections C, D and E. The flags indicate that commentary is provided in Appendix A on the particular subjects flagged. The commentary headings in Appendix A include the section back-references, thus providing a two-way reference system.



There are no commentary flags in Section A. Definitions, or in Section B. Water Areas.

Appendix A: Commentary – Section C

C1.1 Use of the Terms “Launching Ramp” and “Ramp”

COMMENTARY:

The use of the terms “launching ramp” and “ramp” should not be confused.

A “launching ramp” is a paved sloped surface designed and constructed for launching and retrieving trailer boats and other portable watercraft to and from a body of water.

A “ramp” is a pedestrian walkway on an accessible route with a fixed slope greater than 1:20 (5%) and not greater than 1:12 (8.33%).

See Definitions in Section A.

C1.2.1.3 Launching Lane Shiny-Edge Delineation

COMMENTARY:

A 3 inch “shiny” troweled edge along interior and exterior edges of all launching lanes provides highly visible and durable delineation of launching lanes on multiple-lane launching ramps. The shiny edges should be troweled in the wet concrete immediately following impartation of the V-grooves. Done correctly, the bottom of 1-inch V-grooves (slope width, not depth) will be flush with the shiny edge and the top ridges will stand about 3/4 inch above the shiny edge. After all trowel work is completed the rough ends of the V-grooves should be lightly broomed parallel to the grooves to round over the ends and clear the V-grooves of any concrete waste so that water and debris will flow freely down and out of the lower ends of the grooves. This last operation will make the launching ramp surface more “user friendly” to pedestrian traffic and vehicle/trailer tires.

The 3-inch shiny edge finish along the longitudinal edges of adjacent launching lanes will result in an overall 6-inch wide delineation. This will provide a highly visible launching lane delineation that will be permanent, durable and essentially maintenance free. This type of edge finish also serves as a shallow trough that will receive silt and small debris that washes down diagonal V-grooves and move these materials down the launching ramp. As water levels permit, any buildup of silt and debris at the bottom of the launching ramp can be removed as needed.

Paving grade paint has been used for many years for launching lane delineation. It is visible and effective when first applied, but soon fades and wears under sunlight and traffic. It is also difficult to maintain on the lower portions of a launching ramp because of changing water levels and the problems related to proper surface preparation and application of the paint in a wet environment. Paint is not a suitable option for durable and long lasting launching lane delineation.

Over the years multiple-lane launching ramps have been designed and built using only the V-grooves in a herringbone pattern to delineate the launching lanes. However, experience has indicated that the herringbone pattern alone is insufficient for delineation. Changes in the direction of sunlight either enhance or diminish the visibility of the herringbone patterns. And with time and use launching ramp surfaces become stained and coated with algae or marine growth that also diminishes lane delineation, particularly on coastal launching ramps. The provision of the shiny edges along with the herringbone V-groove patterns is now the standard for launching ramp design and construction.

C1.2.1.3 Bullet #3 Planned Transverse Construction Joints

COMMENTARY:

A “planned” transverse construction joint is one that is provided on the basis of rational and logical decisions previously made and reflected in construction plans and specifications, or one that is made in the field in response to site conditions that could not have been anticipated prior to construction. Such field decisions must be made with the full participation and concurrence of the design engineer, inspector and owner/operator of the project. Lack of advance planning in the provision of adequate materials, equipment and personnel are not to be the basis of determining the “convenient” locations of transverse construction joints.

C1.2.2 Single-Lane Launching Ramps

COMMENTARY:

Generally single-lane launching ramps are not practical, particularly if they are over 100 ft in length. They can be difficult to use because of how narrow they are, particularly for inexperienced boaters with low vehicle/trailer backing skills. However, it may be appropriate and necessary to extend at least one launching lane at remote low-use multi-lane launching ramp sites during periods of protracted low water levels. Such opportunities to extend existing launching ramps don’t come along very often, so the opportunity to extend at least one launching lane is usually advisable if funding is available, and reliable weather predictions indicate that water levels will remain sufficiently low to complete the extension work. Such extensions include drying out and grading the site; placing forms, rock base and steel concrete reinforcement; placing, curing and finishing the concrete surface; removing the forms; placing adequate rock riprap along both edges and bottom of new launching lane; and clearing the site of all debris, trash and equipment.

C1.2.2.2 Single-Lane Launching Ramp Width

COMMENTARY:

As a single-lane launching ramp increases in length, the difficulty of backing a vehicle-trailer increases as well. Therefore, the recommended width of single-lane launching ramps over 50 ft in length is 20 ft. The street-legal width of vehicles and boat trailers is 102 inches (8.5 ft). A 102 inch wide vehicle-trailer backing down the center of a 16 ft wide launching ramp will have 3.75 ft clear on each side of the backing vehicle. On a 20 ft wide launching ramp the clearance on each side increases to 5.75 ft, an increase of 150%. Having this extra “wobble room” on longer single-lane launching ramps significantly increases the driver’s margin of error while backing, and enhances the safe use of the launching facility for both launching and retrieving trailer boats.

It is not advisable to increase the width of single-lane launching ramps to more than 20 ft. To do so is to tempt trailer boat launchers to use such ramps as two-lane launching ramps on busy days such as summer weekends and holidays. Two side-by-side legal-width vehicles with trailers on a 20 ft wide launching ramp will occupy up to 204 inches (17 ft), leaving only 3 ft for clearance on the outside edges and between the vehicles. However, increase the ramp width to 24 ft and the clearance increases to 7 ft, a much more tempting situation for boaters who are impatient and in a hurry to launch and/or retrieve their boats. If there is a clearly identified need for a wider single-lane launching ramp, serious consideration should be given to providing two adjacent launching lanes (total of 30 ft at 15 ft per lane) to meet the need. Such decisions must be tempered with consideration of the total ramp length, the topography of the site and the increased costs of construction.

C1.3.2 Number Of Launching Lanes

COMMENTARY:

The user demand at urban sites is usually greater than at rural sites because of the closer proximity to larger populations of people. The user pressure on summer weekends and holidays can precipitate faster launching and retrieval of boats, especially if local staff is present to direct the flow of traffic during peak hours. User pressure at rural sites can be high on holiday weekends, but is typically lower than at urban sites.

User demand can change in response to climate, legal, social and economic changes. For example, during periods of multiple-year droughts (up to seven back-to-back years), such as California experienced in the 1970s and again in the 1980s, water in mountain lakes and reservoirs dropped to record low water levels. As the available water surface areas diminished each continued year of drought, trailer boaters headed down to the valleys and lowland waterways. This resulted in increased trailer boating activity in low elevation waterways including rivers, coastal bays, and the Sacramento-San Joaquin Delta. But it also resulted in increased density of boating on the shrinking lakes and reservoirs. In addressing these situations and conditions, consideration must be given to the age of the boaters and

the type of boating they typically participate in. This will include the use of personal watercraft, ski boats, fishing boats, etc., used by people of varying ages and competence in operating recreational boats. In various ways these factors impact user demand and use of a boat launching facility.

C1.4.2 Multiple Lane Launching Ramps

COMMENTARY:

The pairing of launching lanes provides an open 2-lane ramp width of 30 ft between boarding floats. This is greatly appreciated by boaters including experienced and novice boaters alike. Backing down a single-lane launching ramp with boarding floats on both sides is somewhat like backing down a bowling alley at low water. Boaters need a margin of error in backing their vehicles and trailers. A 2-lane open arrangement also reduces damage to boarding floats from vehicles and trailers backing into the floats.



8 lane launching ramp with 2 pairs of three adjacent boat launching lanes bordered by 2 single lanes

C1.4.3 Launching Ramps with Three Launching Lanes

COMMENTARY:

The center lane of a three-adjacent-lane launching ramp cannot have a boarding float. Therefore, the center lane is essentially an “orphan” launching lane except on very busy summer weekend days and holidays when boat launching and retrieving demand is high. Over the past 20-30 years a number of existing three-lane launching ramps have been expanded to four lanes to provide additional launching capacity and to solve the typical problems inherent in three-lane launching ramps. Four launching lanes can be serviced by boarding floats on both outside edges to serve lanes #1 and #4, and a third boarding float in the center to serve lanes #2 and #3.

There may, however, be local situations where a boat launching facility is a component of a large marina, and the local fire marshal may insist on three adjacent launching lanes. A layout of three adjacent 15 ft wide launching lanes provides a 45 ft wide emergency access for firetruck and fireboat access to a boat on fire at the launching ramp, or nearby in the marina.

C1.4.4 Mixed Launching of Powerboats and Non-Motorized Boats

COMMENTARY:

It is not recommended that powerboats and non-motorized watercraft be launched together. The designated launching lane can be separated by a boarding float that acts as a barrier between the two types of launching lanes. This can be particularly useful at coastal locations where growing numbers of sea kayaks and other paddlecraft are being launched and retrieved on traditional launching ramps. An even better solution is to move paddle craft ingress and egress to a separate location at the facility, if possible.

C1.5.1 Establishing Design High and Design Low Water Elevations

COMMENTARY:

The determination of design high and design low water elevations is not to be determined on the basis of data alone. There will often be other factors that play significant roles in the final determination.

For example, at a high elevation lake subject to large annual water level fluctuations, the normal boating season may be restricted due to early and/or late season access problems resulting from storms, rain, snow, ice, etc.

Another example is a site that is infrequently impacted by extended droughts and a series of winters with lower than normal rain and snowfall. Rather than extending all launching lanes at such a site down to an extreme low water elevation, the problem can be temporarily addressed by extending a single launching lane to address late season boating that is the exception rather than the rule. Such a prudent decision helps limit operation problems, and saves a good deal of construction and maintenance funds.

C1.6.2 Head-of-Ramp Elevation

COMMENTARY:

The head-of-ramp elevation should consider:

- the characteristics of the water body;
- exposure to currents, waves and surge;
- the operational boating season; and
- the estimated consequences of temporary inundation of the head-of-ramp and adjacent parking areas, driveways, restrooms, potable drinking water facilities and landscaped areas when water levels exceed design high water.



inundated launching ramp

In some cases, periodic inundation of an entire boat launching facility may be acceptable and thus planned for. For example, a boat launching facility built on a berm along the bank of a river may be well below the tops of the river levees that protect nearby cities, highways, farmland, etc. In such cases, the head-of-ramp elevation is set by the elevation of the berm, and by the projected normal operational water level elevations provided by state and local water authorities.

C1.6.3 Minimum Toe-of-Ramp Water Depths

COMMENTARY:

A minimum of 3 ft of water depth is usually adequate to launch and retrieve trailered recreational boats in both coastal and inland waters. However, at locations where larger sail and power boats are launched it may be necessary to have a toe-of-ramp elevation 5 ft or more below design low water. This is a growing necessity at certain coastal launching ramps. The need for deeper launching depth is based on the following factors:

- longer boats launched on long tongue trailers need additional launching ramp length to float boats off/onto their trailers; and
- deep keel sail boats ride higher on trailers and require deeper water to float sailboats off/onto their trailers.

Typically the transom of a boat on a trailer will extend 4 to 6 ft beyond the centerline of the trailer axle. But the boat engine and transom are not the critical elements here. It is the trailer wheels that require the additional launching ramp length, resulting in a deeper water depth to get the boats off and on their trailers. On trailers with tandem axles, the axle-to-transom overhang will usually be shorter than on single-axle trailers.

Scouring of soil and rock at the toe of a ramp from waves, currents and powerloading engine prop wash can result in trailer wheels dropping off the end of the launching ramp. If the hole is deep enough the trailer frame can come to rest on the launching ramp. Cases like this often require the service of a tow truck, but if not done properly the boat, trailer frame, wheels and axle(s) can be damaged.

C1.7.1 Minimum Launching Ramp Slope of 12%

COMMENTARY:

Launching ramp slopes of less than 12% are not efficient regarding launching and retrieving trailer boats. Flatter slopes require towing vehicles to back too far into the water to launch or retrieve boats. This can result in immersing towing vehicle tail pipes, rear tires and brakes. Salt water is corrosive and should never be allowed to enter a tail pipe, muffler or other exhaust components. Rear brakes may not function properly until they are drained and the brake system is dry. It is unavoidable for trailer wheels to be immersed in the water when launching and retrieving boats, but this should not be the case with the towing vehicles.

Also, launching ramps with sub-12% slopes cost more because of the extra length compared with steeper launching ramps. The extra cost includes more earthwork, grading, base rock, forming, concrete, rock slope protection and labor. Using an example of a boat launching ramp on a lake with an average annual drawdown of 50 ft, the table to the right shows the significant difference in the required lengths of a launching ramp at various slopes.

| Launching Ramp Length Data for 50 ft of Drawdown | | |
|--|-------------|-------------------------------|
| Slope % | Length (ft) | Percent of Length of 12% Ramp |
| 5 | 1001 | 238% |
| 6 | 834 | 199% |
| 7 | 716 | 170% |
| 8 | 627 | 149% |
| 9 | 558 | 133% |
| 10 | 502 | 120% |
| 11 | 457 | 109% |
| 12 | 420 | 100% |
| 15 | 337 | 80% |

C1.7.2 Change of Grade of Launching Ramp Slope

COMMENTARY:

For example, if a boat on a trailer is launched with a long shaft outboard engine in the down position, the skag and/or prop at the bottom of the shaft housing may strike the flatter slope ramp surface before the trailer wheels reach the bottom of the shallow valley. An engine on the stern of a boat on a trailer is several ft further down the launching ramp than the centerline of the trailer wheels. Therefore, the engine will pass over the low point of the ramp's "shallow valley" before the trailer wheels do. As the trailer and boat continue down the ramp the lower end of the engine will get progressively closer to the ramp surface until the trailer wheels bottom out at the low point of the "shallow valley." Only from that point downward will the wheels begin to roll on the flatter ramp slope and begin to lift the rear of the boat and the engine clear of the ramp surface. The towing vehicle and hitch will continue down the steeper part of the ramp, thus lifting the rear of the trailer and the engine. If an engine strikes the ramp surface, it can result in moderate to severe damage to the engine, the boat, the trailer and perhaps the ramp surface.

C1.8.1 Vertical Curves on Launching Ramps

COMMENTARY:

Where a vertical curve is not provided above the top of a launching ramp, there will be an abrupt change in grade between the launching ramp and the driveway that leads to the launching ramp lanes. The greater the difference between the slope of the driveway and the uniform slope of the launching lanes, the more severe the abruptness of the ridge. The problem is greater on a 15% ramp than it is on a 12% ramp, the range of launching ramp slopes. Whether a vehicle drives forward down a launching ramp towing a trailer, or backing down causing the trailer to pass over the ridge first, the ridge will be chipped and broken by the dragging contact with trailer hitches and safety chains. Gradual damage will wear down the ridge surface and possibly damage trailer hitches. It may also occasionally cause a trailer to disconnect from a vehicle trailer hitch resulting in damage to both vehicle and trailer. It is imperative that recreational boaters provide legal safety chains connected between towing vehicles and trailers.

Additionally, the absence of an apron and a vertical curve at the top of a launching ramp can cause visibility problems. A driver will have to approach, turn and align the vehicle and trailer with a launching lane that cannot be seen unless painted stripes are provided on the driveway above the launching ramp. If no vertical curve exists, particularly on steeper launching ramps, the trailer will temporarily pass out of the driver's rear view line of sight when the trailer is backing down the slope of the launching ramp while the vehicle is still backing on the relatively flat slope of the driveway. The impairment of rear vision will be most severe when the rear tires of the towing vehicle are exactly at the head of the launching ramp. As the vehicle's rear tires pass onto the launching ramp slope, the rear view vision will gradually improve until the front tires pass onto the ramp. At that point both the trailer and the towing vehicle will be on the same plane, the sloped surface of the launching ramp.

On non-vertical curve launching ramps less than 200 ft long with three or less adjacent launching lanes, the impairment of rear view backing will be a continuous problem. In such cases, the launching ramp is not long enough to warrant a turn-around area, and is not wide enough for vehicles and trailers to drive down the ramp slope and make a 180 degree turn to align the trailer for launching or retrieval of a boat. This necessitates all vehicles and trailers to be backed down over the head of the launching ramp regardless of seasonal water levels.

Site topography will ultimately dictate whether it is more functional to build a vertical curve into, or part of, the upper 20 to 25 ft of the launching ramp lanes. Sometimes at sites where the parking lot and apron are only a foot or two higher than the head of ramp, a half-and-half arrangement works best with the length of the vertical curve extending over both the lower area of the driveway and the upper area of the launching lanes. In such a case, the lower area of the driveway and the upper area of the launching ramp would function as the apron, including a vertical curve.

C1.8.2 Full Width and Length Concrete Ramp Aprons

COMMENTARY:

Over the past 20-30 years it has consistently been observed that AC ramp aprons are not durable in salt water coastal locations. The ramp apron typically is a drip zone for vehicles and trailers just removed from the water. Boaters often stop on the apron to secure their boats and trailers, especially where a facility does not have a boat-ready area. Dripping water carries varying amounts of salt, silt, debris and other matter, gradually eroding away the fine particles in the AC paving. This gradual process gradually causes the pavement to fail, the eventual loss of the small pavement aggregate occurs. Unless maintained and repaired, pot holes and erosion of the base rock will occur and ruin the paving.

C2.1.1.2 Actual Minimum Slab Thickness

COMMENTARY:

Typical 2x8 S4S (surfaced 4 sides) form lumber is about 7-1/2 inches wide, or less. Therefore, it cannot be used to form an 8 inch thick launching ramp slab unless the lumber is widened with nailing strips to bring it to a full 8 inch minimum width.

The raising of too-narrow form boards on form stakes to meet required slab thickness by filling in below the forms with rocks and soil is not acceptable. Also, raising the forms on form stakes and letting wet concrete flow out from under the forms until it stiffens and closes the gap is equally unacceptable.

C2.1.1.4. Epoxy Coated Rebar

COMMENTARY:

If epoxy coated rebar is used, damage to the epoxy coating must be minimized during transport, handling, placement in forms, and in placement of the concrete. Damage to the epoxy surfaces should be repaired with a 2-part epoxy coating

approved by the rebar supplier. During placement of the wet concrete plastic headed concrete vibrators should be used to avoid damage to the epoxy coated rebar.

C2.1.1.6 Cutoff Walls and Launching Ramp Slabs

COMMENTARY:

Cold joints between cut-off walls and launching ramp slabs will eventually allow intrusion of water and other corrosive materials that will begin to corrode the reinforcement steel. This will lead to breaking down the bond between the reinforcing steel and the concrete, which will gradually diminish the strength of the joints and jeopardize the integrity of the launching ramp. Cold joints are particularly problematic in salt water environments.

C2.2.3 Precast Concrete Panel Keys

COMMENTARY:

Lifting the precast concrete panels with a slight tilt works well as each panel is lowered and eased downslope as both the lower flange of the female key eases into place. A good balance of the width, depth and slope of the keys is necessary for successful keyed joints. It is recommended that the lowest panel (the first one to be placed) be formed with no key along the downslope edge in order to provide full bearing of the panel against the vertical catch cleat provided at the lower end of all skid rails. If some future extension of the launching ramp is anticipated, the female key on the downslope face of the bottom panel will provide sufficient bearing against catch cleats until the future work is performed.

“Keyless panels” are easier to cast, handle and place since casting yard workers and contractors don’t have to worry about cracking and breaking keys. However, short-term and long-term success in using keyless panels is critically dependent on the long term stability of the sub-base and base rock. It must be uniformly spread, graded to the design slope and compacted to provide a reliable platform upon which the non-keyed panels are to be laid. When compaction cannot be attained (such as a submerged condition), keyless panels should not be used. Additionally, the perimeter edges of the non-key panels must be protected against undermining the rock base. This can be done with fabric and riprap at least 5 ft wide and 16 inches deep. See Section C2.1.1.5 for information on perimeter cut-off walls, wall depth, riprap and fabric.

Keep in mind that using non-keyed panels eliminates the potential problem of breaking keys, but it also eliminates any backup of support between adjacent panels. The keys are not only valuable for the original placement and alignment of the panels, but also for future stability if undermining occurs under the launching ramp. The keys provide “a bridge over troubled waters” even when we don’t know it is happening below the launching ramp. Keys are rather inexpensive insurance.

C2.2.5 Precast Concrete Panel Alignment Rails

COMMENTARY:

A typical 2-lane launching ramp with a single 8 ft wide boarding float will be 38 ft wide. For this arrangement, three skid rails work nicely: one down the centerline and one down each side approximately 4 ft in from the outside edge.

The length of the skid rails will be determined by the width and number of precast concrete panels required to complete the precast section of the launching ramp.

Each of the skid rails should extend approximately 3 ft upslope beyond the top precast concrete panel. This will allow maneuvering room for sliding the last panel into place as well as for anchoring the upper end of the skid rails in the cast-in-place concrete to be placed after the precast panels are in place.

A 3-ft steel anchor leg (made from the same rail material) is to be braced with a heavy steel plate gusset or diagonal brace, and securely welded perpendicular to the bottom of the upper end of each skid rail. After the skid rail has been placed, leveled and secured on the launching ramp slope, these anchor legs will then be anchored in concrete filled holes under the top end of each skid rail. These anchor legs will prevent the railings from moving downhill during installation of the panels, and will prevent future sliding of the heavy launching ramp from the influences of gravity, vehicle traffic and possible seismic activity.

At the foot of each skid rail, weld a short length of the same railing material to the end of the rail to serve as a catch cleat during the placement of the first panel. The cleat must extend upward perpendicular to the rail, be approximately 1 inch shorter than the thickness of the precast panels, and chamfered 45 degree on the downslope face to eliminate sharp edges that may become exposed during low water periods. The catch cleats at the foot of each skid rail must all be in perfect alignment. This will ensure that the first precast panel placed comes to rest against all of the catch cleats, and the precast panel is in proper alignment and square with the centerline of the launching ramp. This will give maximum support for the precast panels.

Following is an example installation of skid rails for placing precast concrete panels. However, there are other methods that have been used successfully. The objective is to provide reasonable and effective ideas and advice for use on future projects.

Precast Concrete Panel Placement Procedure (PCP)

PCP Step 1: Fabricate the railing framework on shore, including:

- two to four skid rails depending on the width of the launching ramp;
- cross spacers to maintain skid rail spacing and alignment;
- diagonal cross bracing for stability and rigidity (not often necessary);
- 3 ft long braced anchor leg under top end of each skid rail; and
- 6 inch high “panel catch cleat” at the lower end of each skid rail (see next page).

PCP Step 2: Place, compact and grade the first layer of base rock, both above and below the waterline as required.

PCP Step 3: Dig the skid rail anchor leg holes approximately 16 inches in diameter and 42 inches deep. This will provide “wobble” room necessary when positioning the railing framework. After the holes are filled with concrete, the anchored rails will serve as a reliable foundation that will resist movements from the effects of gravity, waves and seismic activity.

PCP Step 4: Lift the railing framework and position it in its final location, inserting the vertical skid rail anchor legs down into the anchor holes in the rock base and sub-base material. Care must be taken not to rack or twist the assembled frame when moving and positioning it.

PCP Step 5: Make the necessary adjustments to ensure that:

- all skid rails are in full contact with the first layer of base rock;
- all skid rails are in the same plane at the design slope;
- all catch cleats are perfectly aligned at the lower end of push rails; and
- all anchor legs are 6 inches clear of sides of anchor leg holes.

Note: If necessary, provide 12 inches x 36 inches x 1/4 inch steel bearing plates at 10 ft intervals under the skid rails to provide additional bearing on the base rock. There will be some necessary handwork to work the rock around and under the bearing plates with steel rods and tamping bars to raise or lower various bearing points to correctly and accurately place the push rails. The most difficult task is accurate placement of the lower sections of the push rails if they are under water.

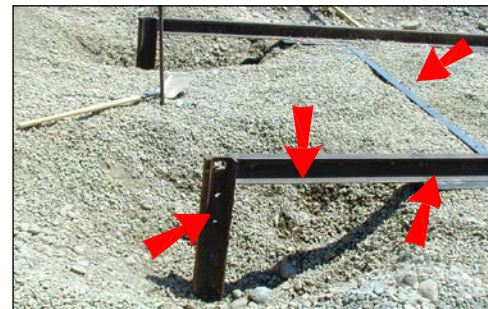

components that can be used: anchor legs, skid rails, bearing plates, cross braces and panel stop blocks shown under water

PCP Step 6: After the railing framework is in place, fill all of the anchor leg holes with concrete up to the top of the compacted base rock. Place the concrete in two or three lifts, rodding each lift to ensure full bond between steel and concrete and the elimination of all voids. To allow the anchor concrete to cure and gain strength, the railing framework should be in place at least seven days prior to placement of the upper base rock and the precast panels.

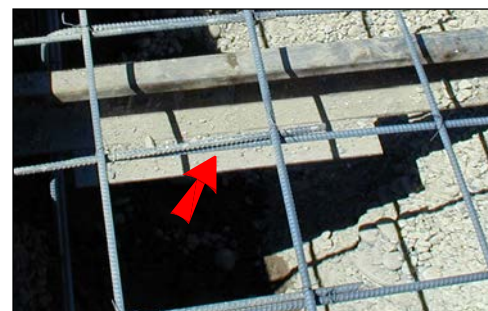

bearing plate welded under skid rail

PCP Step 7: After the railing framework is installed, place the upper layer of base rock flush with the top of the skid rails. It is recommended

that small round rock such as pea gravel is used for this purpose. Dump it at the head of the launching ramp, and use the skid rails as screed bars as the rock is leveled and compacted. The pea gravel is easy to work and plows nicely while screeding the gravel flush with the top of the skid rails. A small crane off to the side of or at the top of the launching ramp can drag a light beam or piece of railing up and down the skid rails until the surface is flat, clean and ready for the placement of the precast panels. The compacted pea gravel must be confined along the edges of the launching ramp with fabric and riprap as necessary to prevent movement of the gravel both during and following construction.

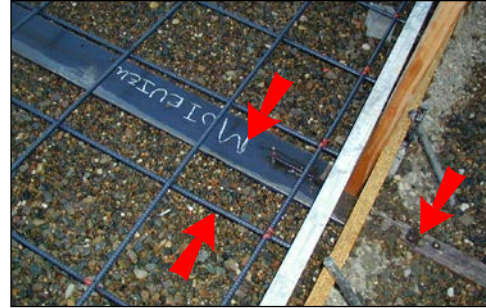

before concrete is placed, base rock is screeded to top of skid rail, upside down channel is welded to rebar and slides on top of the skid rail which is seen at lower right corner

PCP Step 8: Lift the first precast panel and gently lower it into the water and place it on the skid rails a few inches upslope from the catch cleats at the lower ends of the skid rails. Using a diver, make sure there is no gravel on the tops of the rails, and that the first panel is straight and true to the centerline of the launching ramp. Then slide the panel down and seat it firmly against the catch cleats. **It is absolutely critical that the first panel be set properly.** If it is skewed, out of alignment or cocked up on gravel on the rails, the panels will not nest together correctly and the error(s) will multiply and telegraph up through all of the other panels resulting in a poor installation job.



precast panel is nearing catch cleat as worker clears away plowed gravel

PCP Step 9: Continue placing the panels with the keys of each panel correctly matched for nesting together. Lift and place each additional panel on the skid rails a few inches upslope of the previously placed panel, clear all gravel in the keys, and skid each panel snugly into place.



completed precast panel launching ramp

C2.4.2 Concrete Push Slabs

COMMENTARY:

In recent years a push slab weighing up to 360,000 pounds (180 tons) has been successfully constructed and pushed into place.

When building launching ramps in tidal waters, two push slabs can be used. Construct, cure and push the first slab into position. Construct, cure and push the

second slab leaving a 2 to 3 ft gap between the two slabs. Construct a cast-in-place V-grooved concrete closure slab between the two push slabs as soon as water levels permit. Select a low tide and have everything ready to go. Place quick setting concrete, V-groove the surface and broom the closure slab before the next tide submerges the new concrete. Try to align the V-grooves with the two push slabs. Attention to details such as continuous steel reinforcement through such closures is critical to the structural integrity of the launching ramp. See Section C2.2.8 for closure pictures.

The advantage of push slab construction compared to using precast concrete panels is improved stability and the elimination of almost all of the joints across the width of a launching ramp. In some river and coastal settings exposed to severe flood, tide and/or surge water influences, precast panels are subject to undermining from loss of rock base from under the panels. This can lead to gradual sagging of the guiderails and panels, and failure of the launching ramp over time. Push slabs are large, heavy, monolithic structures that can withstand substantial undercutting, thus providing time for discovery of such problems and the implementation of remedial actions.

The length of a push slab will be determined by the water depth during the period of construction, and the configuration of the shoreline immediately above the launching ramp site. The site will have to be prepared for construction and pushing of a slab. Following completion of pushing the slab, the shoreline will have to be restored or otherwise prepared to use for access to and from the completed launching ramp.

Types of Concrete Push Slabs

Where it is necessary to use push slabs, the following types are recommended for the locations and conditions described:

Type A: At coastal locations, larger lakes, reservoirs and rivers, a push slab/ guiderail system utilizing two or more guiderails is recommended. This system facilitates movement of a push slab down the slope, maintains alignment and assists in monitoring the final position of the slab. Align the guiderails about 1/4th of the slab width in from the outside edges, a layout that will balance the position and weight of the slab evenly over the two guiderails. This will also provide a clear path between the guiderails for a track-type tractor(s) to push wider push slabs of two or more launching lanes in width. Guiderails must extend upslope not less than 1-ft beyond the location of the upper edge of the push slab form where the slab will be built, and long enough to push the cured slab to its lower edge design elevation. Catch cleats must be provided at the lower end of all guiderails to secure the slab at the design elevation and arrest any future movement down the launching ramp slope.

Type B: At small quiet lakes and reservoirs, not subject to strong waves, large boat wakes, or currents, push slabs with continuous steel base plates can be

used in the construction and pushing of smaller, lighter single-lane push slabs. This system is easier and less expensive than the guiderail system, requiring less labor, equipment and materials. Either 18 gauge flat steel plate or 18 gauge corrugated steel roofing works well. It is easy to handle, relatively inexpensive, and the steel rebar cage in the launching ramp slab can be spot-welded to the bottom plate to secure it in position. If corrugated steel roofing is used, the thickness of the push slab must be measured from the top of the corrugations to the bottom of the V-grooves. Such push slabs are relatively easy to push, are usually pushed in 20 to 30 minutes, and require only one tractor dozer to make the push. The steel bottom plate will eventually rust, but it's only essential function is to facilitate easy movement of the push slab during construction. The lower ends of rebar welded to the bottom plate will also eventually rust, but in fresh water installations, this should not jeopardize the service life of the launching ramp.

C2.4.3 Rail Guided Push Slabs

COMMENTARY:

A large D9 track-type tractor is 8 to 9 ft in overall track width. A minimum clear width between the guide rails of 12 ft is advisable to provide wiggle room for operating the tractor without damaging the guiderails. Since the blade on the front of a large tractor will be operated above the guide rails, the width of the blade is of no consequence regarding spacing of the guiderails.

C2.4.4 Push Slab Flag Sockets

COMMENTARY:

A good scheme is the use of red flags on the guide rails and white flags on the push slab. The sockets must be attached in accordance with the design slope of the launching ramp such that the inserted flag poles will be vertically plumb and stable. A stop pin at the bottom of the sockets or shoulder sleeves 4-6 inches above the lower ends of the flag poles will control penetration of the poles into the sockets. The length of the flag poles necessary for good visibility will be dictated by the length of the push slab, the launching ramp slope and the water depth during construction. As the slab is pushed, the movement of the push slab relative to the end of the guiderails is clearly evident from the flag poles, a very valuable visible reference in the execution of the work. After completion of the pushing operation, simply pull out the poles and flags. Do not locate the flag sockets on the guiderails such that the sockets will obstruct seating the push slab against the stop cleats.

C2.4.5 Rail Stops

COMMENTARY:

Rail stops will provide some degree of insurance against the push slab slipping down the slope in the event of local seismic activity during the first couple of years after construction. After a year or two, the push slab and guiderails will be "mudded in" and most likely stable for the duration.

C2.4.6 Anchor Legs Under Guiderails

COMMENTARY:

Excavate holes for guiderail legs. Make sure railings are on grade and in the same plane for full bearing of the push slab(s) on the railings and gravel underbase after construction is completed. Once the guiderails and anchor legs are in place, secure all anchor legs in the excavated holes with concrete. Anchor legs and remaining guiderails under the push slab will remain in place permanently to help keep the launching ramp in place when exposed to waves, currents, settlement and/or seismic activity.

Construction and pushing of a concrete push slab (**CPS**) should generally comply with the following procedure:

CPS Step 1.

Prepare the shoreline immediately above the launching ramp location (see C2.3.3 above). The length of the earth ramp above the waterline must be long enough to construct the push slab and to position a D8 or D9 tractor immediately above the push slab to begin the pushing operation. On larger, heavier push slabs, it may take two such tractors in tandem to break the slab loose from its initial position. After that, one large tractor should be able to push the slab down the launching ramp slope to its final position. Do not underestimate the size of tractor(s) necessary to initially break the push slab loose from the base rock, and the length of compacted earth ramp above the slab necessary to accommodate the tractor(s).

CPS Step 2:

Cover the temporary earth ramp and entire ramp area below the waterline with base rock. The initial depth of rock will be determined by the height of the guide rail that will rest on this base rock. Grade, tamp, and compact this first layer of base rock to the required slope, grade and compaction. It may be difficult to obtain the rock compaction specification used on dry land applications on the base rock below water. This is a construction situation in which common sense should prevail. The engineer in charge, inspector and contractor should work together to obtain the best rock base grading and compaction reasonably possible under the existing conditions when working under water. Push slabs are large monolithic structures that will essentially have full bearing on the base rock, a situation that is tolerable of lesser degrees of rock base compaction provided that the rock is confined around the edges of the completed launching ramp.

CPS Step 3:

Place, align, level and secure the guiderails and anchor legs. Excavate holes for guiderail legs. The guiderails will be partially buried in the base rock with the top of the rails about 2 inches above the compacted base rock. To properly achieve this marriage of guiderails and compacted base rock will be a little tedious and will require some hand work with steel bars, picks and shovels to align the rails

and work the rock under and around the guiderail bearing plates. The bearing plates should be similar to those recommended for precast concrete panels. Make sure the guiderails are parallel, at the same design slope, and are all in the same plane at all points along the length of the guiderails. The rail stops at the bottom of all guiderails must be perfectly aligned with each other to properly support the push slab.

CPS Step 4:

With the compacted base rock up to within 2 inches of the top of the guiderails, dump and spread pea gravel over the base rock. Use a small crane and a suitable length of steel beam or railroad rail to level and screed the pea gravel flush with the top of the guiderails. This operation will also compact the pea gravel and work it into the base rock to some extent. The final thickness of the pea gravel will be about 2 inches between the top of the base rock and the top of the guiderails. The pea gravel will facilitate pushing the slab.

CPS Step 5:

Install the push-slab forms over the guiderails and pea gravel base, providing the necessary slab thickness to meet structural requirements, and minimum steel rebar cover for fresh or salt water installations (see C2.1.1.1).

- Locate the lower end of the push slab form to avoid any encroachment of water within 10 ft (slope distance) of the bottom end of the form during the anticipated construction period. This will keep the lower end of the form free of standing water, will allow adequate working space for the construction crew and will provide a margin of error necessary if the weather forecast changes. Keep in mind that the upper edge of a 10 ft wide working area will be only about 18 inches above the waterline on a 15% (1:6.67) slope, and about 14 inches on a 12% (1:8.33) slope. If site conditions allow, increase the working area width up to 15 ft, especially if water levels are expected to rise during construction of the push slab.
- Locate the upper end of the push slab form not less than 12 inches below the upper end of the guiderails. ***This is a critically important detail!*** If the upper ends of the guiderails are inside the forms, wet concrete will flow down and around the ends of the guiderails. This will create an obstinate barrier to later pushing the slab, resulting in damage to the upper end of the slab and/or the guiderails.

CPS Step 6:

Fabricate two full-length steel guide channels to fit over the guiderails inside the push slab forms, using a size that will fit loosely over the top of the guiderails with the flanges down. Lubricate both the top of the guiderails and the inside surfaces of the channel webs and flanges with an environmentally approved water-soluble biodegradable lubricant, and lay the channels over the guiderails. Weld vertical

stirrups to the top of the channels at appropriate locations for later attachment of the steel reinforcement. Both the guiderails and the channels must be smooth and straight to facilitate movement of the push slab.

CPS Step 7:

Install an “L” shaped heavy gauge sheet metal bull nose to cover the entire lower form face and the lower 2 to 3 ft of the pea gravel and guiderails. The bull nose should be crisp and sharp to facilitate plowing of the rock in front of the push slab during the pushing operation. Properly installed, the sheet metal bull nose will keep the top of the guiderails clear of rock and discourage the push slab from riding up and over the rock.

CPS Step 8:

Cover the entire rock base surface inside the forms with not less than 18 gauge steel sheet metal, securing it to the topside of the sheet metal bull nose and the side forms. Do not cover the top of the steel guide channels with sheet metal as this would prevent bonding between the concrete and the guide channels to which the stirrups are welded. The bottom of the smooth sheet metal surface will serve as an interface between the concrete push slab and the pea gravel base. The reduction in friction will make it easier to get the push slab started, and pushing to the design elevation will be accomplished with greater control. This method will usually make it possible to accomplish the work with (1) smaller tractors, (2) fewer tractors, and (3) lower cost.

CPS Step 9:

Install the required steel reinforcement in the forms, securing it to the stirrups on the channels (see CPS Step 6 above), taking care to provide the necessary concrete cover over the steel at both the top and bottom surfaces of the push slab. The longitudinal steel should be extended through holes in the upper end form by about 20 rebar diameters for later use in tying the rebar to a second push slab, or the ramp apron to be built upslope from the push slab.

CPS Step 10:

When all preparations have been completed, construct the push slab in much the same way as a conventional launching ramp slab. Start placing the concrete in the forms starting at the bottom and work uphill. Pay close attention to the concrete mix, slump, vibration, V-groove finish, and shiny edge finish work.

CPS Step 11:

After removal of the forms (not recommended sooner than 48 hours to protect the fragile V-grooves) and the required curing period, position large wood timbers along the upper edge of the push slab to act as a cushion between the push slab and tractor blade. The timber should be square in cross section of a size not less in height than the thickness of the push slab, not less in width than 1 inch more than the length of the protruding rebar, and at least several feet longer than the

track width of the tractor. Drill matching holes in the cushion timber and fit the timber over the rebars and up against the face of the push slab. This will protect the rebar, and the rebar will hold the timber cushion in place during the pushing operation. If the protruding steel rebar is exceptionally long, it can be carefully bent vertically, and protected by wood blocks during the pushing operation.

CPS Step 12:

Grease the surface of the guiderails between the push slab and the waterline with environmentally approved water-soluble biodegradable lubricant, and insert all flags into the sockets on the guiderails and the push slab. Place and maintain a windrow of pea gravel along the lower edge of the push slab as it is being pushed. This will cause all surface voids to be filled in the base rock as the slab plows and cleans the surface as it moves down the slope on the guiderails.

CPS Step 13:

Move the tractor(s) down against the cushion timber at the head of the push slab. It will probably require a sharp bump or two by the tractor(s) to break the push slab loose and begin movement down the slope. Slowly push the slab down the guiderails, stopping at a couple of points along the way to ensure that the slab is still in full contact with the guiderails at both the top and bottom edges of the slab. Resupply the windrow of pea gravel along the leading edge of the slab as movement continues. Continue to move the slab down until the flags indicate closure is nearly complete. Stop the push slab a few inches from the rail stops and perform an “in-the-water” inspection to make sure that all “plowed rock” is cleared from around the rail stops and on the guide rails. Push the slab into its final position against the rail stops.

CPS Step 14:

Do a final check to assure that the guiderail system has not slipped or otherwise moved, and that the toe of the push slab is at the specified elevation. Utilization of the guiderail system will provide a high probability that everything will be according to the plans and specifications.

C2.6.5 V-Grooves Under a Boarding Float

COMMENTARY:

A coarse broom finish perpendicular to the long axis of the launching ramp is a good finish under a boarding float. It will allow silt and other debris to flow down and away from the floats and off the toe of the launching ramp. This is particularly effective under boarding floats that are positioned between launching lanes where herringbone V-grooves move silt under the floats from both sides. The broom finish surface below the floats can serve as a wide shallow trough to move material down the launching ramp. Making wise use of V-grooves 60 degree right and 60 degree left, or both in a herring-bone pattern, broom finishes and the appropriate location of boarding floats with regard to local conditions will provide a rational basis for determining whether V-grooves should pass under the boarding floats.

If a broom finish is provided under boarding floats, silt and debris will either move down and off the toe of the launching ramp, or collect on the toe, depending on the topography, seasonal water depths, currents, etc. If such materials do accumulate over time, they can be removed and hauled away as low water opportunities occur. Permits may be required for the removal and disposal of silt and debris.

C2.7 V-Groove Tool Design and Fabrication

COMMENTARY:

V-groove tools for finishing launching ramp concrete should have the following design and fabrication characteristics.

V-Groove Tool Basics:

- Weight: 22 to 25 pounds
- Length: 24 to 30 inches
- Width: 12 to 24 inches, depending on material and weight
- Material: 1 inch x1 inch x 3/16 inch metal angle bars (aluminum preferred)

V-Groove Tool Fabrication:

Step 1. Cut, shape, weld and grind smooth both ends of the necessary number of angle pieces to resemble long skinny V-bottom boats with bows at each end.

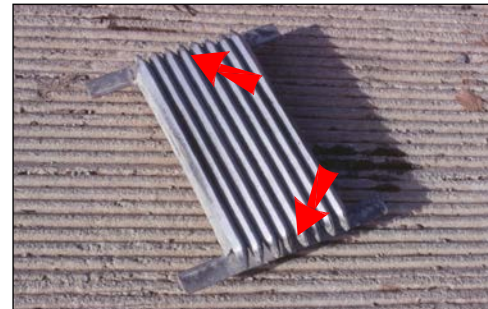

bow shaped v-groove finish tool

Note: Some contractors and concrete finishers have suggested cutting the trailing edges of the tool square rather than bow shaped. They claim that the wet concrete breaks free of the trailing edge much sharper and cleaner than it does from the gradual release from a bow shape. Also, some contractors prefer to build lighter tools and add field weights as needed to get the best results and production.

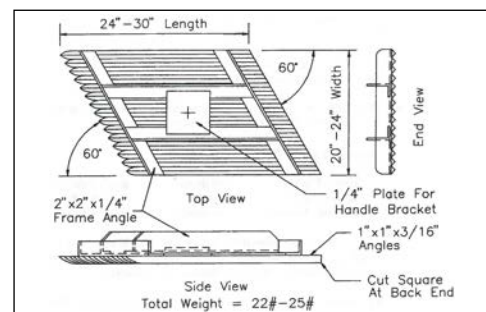

v-groove finish tool

Step 2. Assemble the pieces of angle bars to form a tool of the necessary width. Fit them snugly together on a flat work surface with the flanges up, staggering each piece against a 60 degree assembly jig so as to form a 60 degree angle on both the leading and following ends of the tool. This will make the tool compatible with the standard 60 degree V-groove angle for launching ramp finishes, and enable the tool to fit against the forms on both sides of a launching lane during the finishing process.

Step 3. Weld the angle bars to two or three rigid cross pieces of angle or channel to hold the tool together.

Step 4. Provide an appropriate bracket or socket as a means of attaching a long metal pole with a horizontal pin which allows adjusting and locking the handle at the correct vertical angle. Limited rotation is necessary to enable finishers to alternately tip the leading and following edges up slightly as the tool is pushed across and pulled back over the diagonal width of the launching ramp lanes. This prevents plowing up the wet concrete and facilitates the smooth passage of the bow-shaped tool as it forms the V-grooves. The handle assembly for a “Fresno” float works well. Finishers working from both sides of the launching ramp lane will shorten the reach and speed up the work.

Note: The 60 degree diagonal distance across a 15 ft wide launching lane is nearly 18 ft. Allowing room for a finisher to work and sufficient handle length to operate the finishing tool, the handle will have to be about 22 to 24 ft long. To improve efficiency contractors sometimes attach two handles to the same tool. This enables two finishers to work together, alternating in pushing the tool as opposed to pulling it. This necessitates clear working space along both sides of the launching lane to provide clearance for the long handles. If the work is going smoothly and only one pass of the finishing tool is doing the job, the two-handle arrangement facilitates lifting and relocating the tool for subsequent passes back and forth across the launching lane.

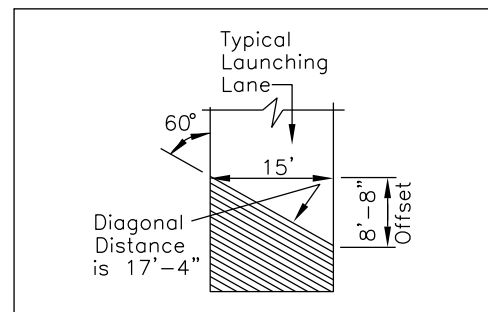

typical launching lane

Step 5. Smaller V-groove hand tools should be fabricated for finishing the beginning corner at the lower edge of a launching lane and at the opposite corner at the top. Additional small V-groove hand tools are also very useful for cleaning up the ends of the V-groove edges along both sides and the top and bottom edges of a launching lane after the 3 inch wide shiny edge finish has been completed (see C1.2.1.3).

It is often helpful to fabricate a couple of 6 inch wide by 8 inches long V-groove hand tools to use in the tight corners at the top and bottom of the launching lane, and to clean up the V-grooves along the edges as required. Such hand-held tools should have the proper 60 degree or 30 degree angles on the leading and trailing edges as necessary for finish work right or left at the bottom and top edges of a launching lane. This is not complicated, but it can be confusing and care must be taken to get it correct for the specific application.

C2.8 V-Groove Launching Ramp Construction Procedure

COMMENTARY:

The following basic procedures have worked well to construct many boat launching ramps over the past 30 to 40 years.

Test Panel. Prior to beginning concrete work on the actual launching ramp, the contractor must be required to make a minimum 4 ft x 8 ft x 4 inch test panel(s) on flat ground at the construction site, using concrete of the same specifications to be used on the launching ramp, including a slump of 3 to 4 inches. One or more test panels must be produced until a panel is approved by the engineer in charge or the project inspector. The approved test panel will demonstrate the contractor's ability to form satisfactory V-grooves in accordance with the plans and specifications, and will serve as an objective visual and performance standard on the site for judging the acceptability of the V-grooves formed on the actual launching ramp lanes.



rejected V-groove test panel

Minimum Crew Size. A minimum crew of not less than five (5) concrete workers, including at least two (2) concrete finishers, is strongly recommended. The minimum crew of five is not to include truck drivers and others who are not fully involved in and committed to placing, vibrating, screeding, floating and finishing the V-grooved concrete launching lane.

Advance Preparation. All rock base, steel reinforcement and formwork is to be in place, inspected and approved; and all tools, supplies, equipment and materials are to be on site and ready for use before beginning placement of any concrete.

Work On One Launching Lane At A Time.

Place concrete and finish one launching lane at a time (or one lane per crew), at a maximum width of 15 ft, and not to exceed 20 ft on single lane launching ramps. There may be cases where V-grooved concrete surfaces will be continued diagonally across boarding float lanes. Typical boarding floats are 8 ft wide, so the overall width of a launching lane and boarding float would be $15\text{ ft} + 8\text{ ft} = 23\text{ ft}$. Extra care will be required to create acceptable V-grooves across this wider diagonal reach of about 27 ft.



on site V-groove test panel

Start Early. Begin concrete work early in the day with attention to:

| | | |
|---------------------|-----------|-----------------------------|
| time of year | altitude | weather forecast |
| temperature | wind | concrete design mix |
| climate | humidity | size of finish crew |
| distance from plant | haul time | road conditions and traffic |

Perform Concrete Slump Test. Perform a slump test to ensure that the concrete has a slump of 3 to 4 inches. This is critical to a successful V-groove finish operation. If the slump is less than 3 inches, the mix will be too stiff and the grooves cannot be formed crisply and quickly. If the slump is over 4 inches, the mix will not be stiff enough and the grooves will slump and lose their form.

Start At Bottom And Work Up. Start concrete placement at the bottom of a launching lane and work uphill. Some concrete contractors insist on starting at the top and work downhill. However, there are at least four good reasons for beginning at the bottom and working uphill.

Reason #1- Truck access is sometimes limited to the launching lane being built. Thus the launching lane must be used to deliver materials, and construct the launching ramp moving uphill. Starting at the top would require the contractor to work over new concrete, possibly breaking the peaks off the V-groove finish and/or cracking the launching ramp slab.



performing concrete slump test

Reason #2- Launching ramps are often built during the fall and early winter months when water levels are lowest, but also when rain and snow are probable at higher altitude sites. Starting at the top of the launching ramp may waste valuable time and access if the water level begins to rise. Starting at the bottom will help ensure that the full design length of the launching lane(s) will be constructed.



start at bottom and work uphill

Reason #3- Even though wet concrete is relatively stiff at a slump of 3 to 4 inches, wet concrete tends to creep downhill under the influences of gravity and working the concrete with vibrators, screeds and floats. Starting at the bottom utilizes gravity in a positive way, acting to hold the wet concrete firm against the bottom form, and against previously laid concrete as the work progresses uphill. Downhill creep will be held to a minimum during the concrete placement and finishing processes.

Reason #4- Perhaps the best reason for starting at the bottom is that a finish crew typically becomes more proficient with experience, and the quality of the finish improves during the construction process. Therefore, it is appropriate for the workers to do the initial work at the bottom of the launching ramp, gain experience as the work progresses, and execute the best work in the upper section of the launching ramp where both the use of the launching lanes and the visibility of the work will be the greatest. Appearance should testify as to the good design, construction and safe use of a well done boat launching ramp.

Rate Of Concrete Placement. For each 8 inch thick / 15 ft wide launching lane, limit the placement of 3-4 inch slump concrete to a production rate of about 30 to 35 linear feet per hour. This will take from 11 to 13 cubic yards of concrete per hour, and will result in a surface area of 450 to 525 square feet. This rate of work also helps the delivery timing of consecutive loads of concrete.

Vibrate Concrete. Adequately vibrate the wet concrete every 12 inches on center each way with internal vibrators to eliminate air pockets, and to ensure full contact with the steel reinforcement and construction forms. Do not over-vibrate as the aggregate will settle to the bottom and weaken the launching ramp slab.

Screed Concrete. Screed the wet concrete flush to the top of the forms using a vibratory power screed, working uphill using hand cranked or gasoline powered winches. Do not attempt to manually drag a vibratory screed uphill, particularly on launching lanes over 50 ft long. fatigue will set in and begin to negatively affect the pace and quality of work being done.

Float Concrete. Float the concrete with wood or metal floats as necessary to touch up and repair the screeded surface in preparation for imparting the V-groove finish.

V-groove Concrete. Begin at the appropriate lower corner, right or left, and begin forming V-grooves at 30 degrees from the horizontal form board across the bottom of the launching lane. Make sure that the diagonal degree and direction of the V-grooves is correct as per the construction plans. If the V-grooves are formed at 60 degrees from the horizontal bottom form board, the grooves will be too steep and vehicle traction will be somewhat compromised.



gasoline powered vibratory screed

The 30 degree V-groove alignment offset from side to side on a 15 ft wide launching lane is 8 ft 8 inches (104 inches). The diagonal length across the

launching lane will be 17 ft 4 in (208 inches). Note that it forms a 30 degree to 60 degree triangle: the diagonal length (hypotenuse) of 17 ft 4 in (208 inches) is exactly twice the length of the side opposite the 30 degree angle, 8 ft 8 in (104 inches).

The use of a straight 20 ft length of 2x6 straight lumber or other relatively lightweight straight edge will be of great assistance in accurately maintaining the correct 30 degree V-groove alignment. The straight edge is easy to handle and will function as a reliable guide for running the V-groove tool across and back over the wet concrete.

SUGGESTION: Better V-grooves can be formed by attaching 1-1/2 inch x 3/4 inch smooth planed removable wood strips along the top edges of the form boards. The wood strips will be removed before the V-grooving process begins, so fasten the strips to the forms with 2-1/2 inch (8d) smooth finish nails for easy removal. **See View A in the V-groove procedure graphic overleaf.**

Where a new launching lane is being constructed adjacent to an existing launching lane, insert “L” shaped sheet metal strips (~4 inch vertical leg and ~12 inch horizontal leg) over the wood strips and the edge of the existing launching lane surface. The sheet metal strips will protect the existing launching lane surface, and will facilitate smooth operation of the power screed.

After the wet concrete has been placed, vibrated, screeded, floated, and the sheet metal and wood strips have been removed, the 3 to 4 inch slump concrete will stand vertically 3/4 inch (0.75 inch) above the top of the forms, the thickness of the removed wood strips. This is almost exactly the depth of 1 inch x 1 inch V-grooves (0.71 inch). As the V-groove tool passes over the top of the form boards, it will form grooves with the bottom of the valleys flush with the tops of the forms, and the peaks 3/4 inch above the forms. **See View B above.** Shiny edges can then be formed along the edges of the launching lane, using small finish tools for edging and cleaning up the V-grooves. **See View C above.**



creating diagonal V-grooves in wet concrete



creating diagonal V-grooves in wet concrete

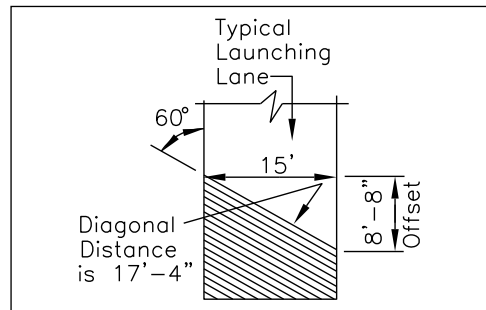

V-groove diagonal dimensions

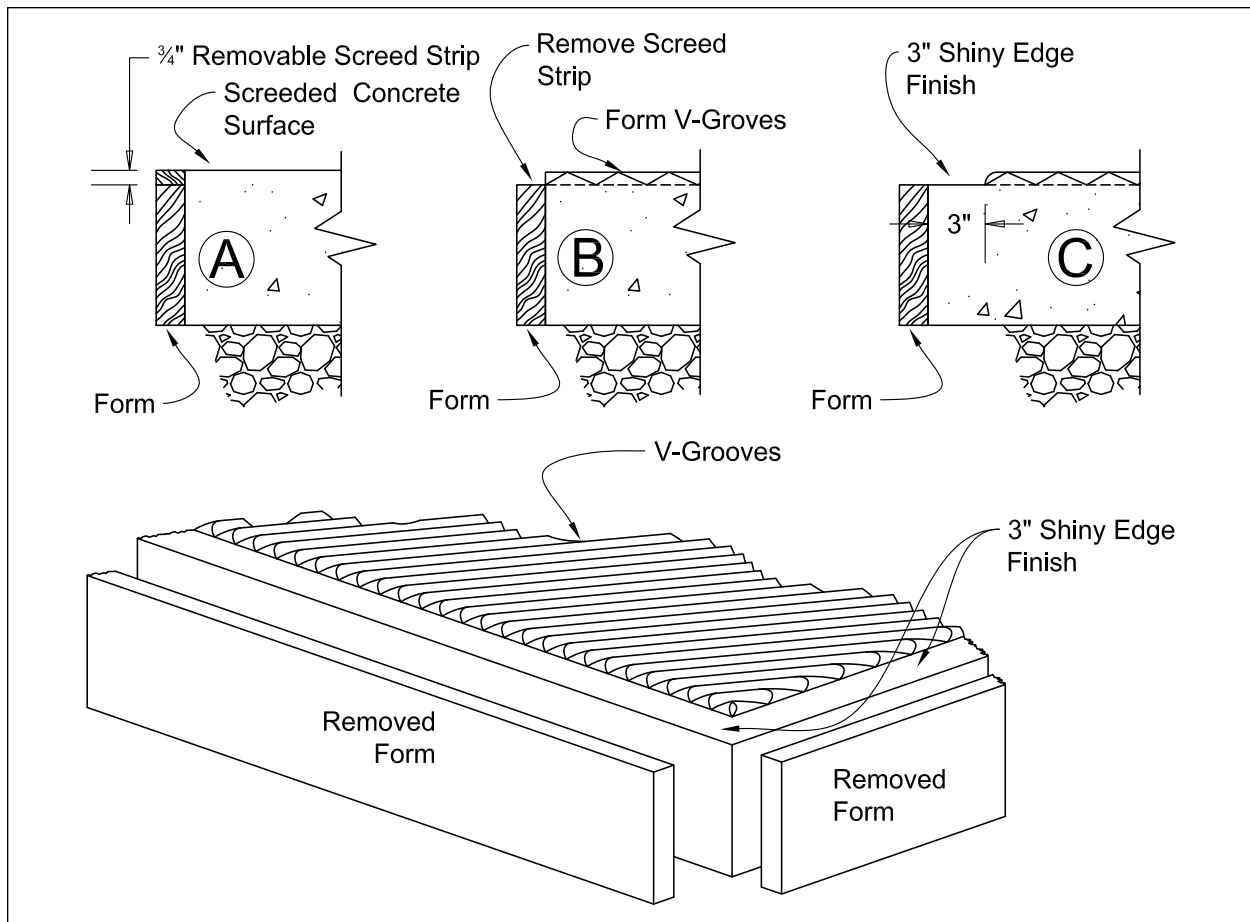

V-groove procedure graphic illustration

If a herringbone V-groove finish is required on multiple-lane launching ramps, mirror-image finishing tools are necessary to form the V-grooves at the correct angles.

If a V-groove tool is used that does not have angled leading and trailing edges, the tool must ride up over the form boards with each pass of the tool. If a tool is 24 to 30 inches long, this riding up movement over the form board produces V-grooves with bottom troughs that slope up near the form board, resulting in V-grooves that do not drain properly and do not effectively carry silt and debris down and off the edge of the launching lane. It is important to have the tool match the angle of the form board, and produce long, straight V-grooves of uniform depth. Drainage of the V-grooves will be enhanced by the 3-inch wide shiny edge along the sides of all launching lanes.

When the procedure is properly executed, crisp V-grooves can be formed with only one or two passes of the tool. If a grooving tool is used from only one side of the launching lane, it will be necessary to have a handle 20 to 24 ft long to comfortably reach across the diagonal width of the launching lane. Some of the extra length is necessary to facilitate use of both hands on the handle

when the tool and handle are at maximum extension. Also, the extra length is useful when a second worker assists in lifting the tool for repositioning to make another pass across the concrete. Aluminum pipe works well for a V-groove tool handle.

Another option is to have two handles attached to hinged connections on the V-groove tool for use by two workers on opposite sides of the launching lane. A rhythm can be worked out between the two workers, alternating between active and passive roles involved in pushing and/or pulling the grooving tool. Grooving tools usually work best when they are pushed rather than pulled.

NOTE: The diagonal V-grooves not only provide vehicle traction, but also can effectively move sand, silt and debris off the outside edges of the launching ramp, and/or down the shiny edges between launching lanes. The most effective V-groove pattern has to be determined on the basis of the number of launching lanes, and site conditions such as prevailing winds and water currents. In a river, for example, the V-grooves should be directed to move the sand, silt and debris in cooperation with the prevailing flow of the river, including consideration to eddies and reversal of water flows caused by curves in the river.



effectiveness of V-grooves in moving silt across and down a ramp

Successive Concrete Placements. Vibrate, screed and V-groove each successive placement of concrete before allowing the next placement. If temporary delays occur between hourly placements due to equipment problems, delays in concrete deliveries, traffic, etc., leave the rough edge along the upper side of the last placement generally along the same 60 degree alignment of the V-grooves. When placement of concrete resumes, this will eliminate most of the problems of trying to finish both “old” and “new” concrete in the zone where the two placements meet. If such delays cause termination of concrete placement for the day, a clean and straight formed construction joint will have to be made across the width of the launching lane against which the next placement will continue on another day. Reinforcement steel must be continuous through such joints. Such ad hoc construction joints are not to be finished with a 3-inch shiny troweled edge finish. When work resumes, make efforts to match the “old” and “new” V-grooves at the construction joint for effectiveness of the grooves as well as appearance.

If a herringbone V-groove finish is required on multiple-lane launching ramps, mirror-image finishing tools are necessary to form the V-grooves at the correct angles.

If a V-groove tool is used that does not have angled leading and trailing edges, the tool must ride up over the form boards with each pass of the tool. If a tool is 24 to 30 inches long, this riding up movement over the form board produces V-grooves with bottom troughs that slope up near the form board, resulting in V-grooves that do not drain properly and do not effectively carry silt and debris down and off the edge of the launching lane. It is important to have the tool match the angle of the form board, and produce long, straight V-grooves of uniform depth. Drainage of the V-grooves will be enhanced by the 3-inch wide shiny edge along the sides of all launching lanes.

Appendix A: Commentary – Section D

D1.1.3 Internal Guide Piles

COMMENTARY:

On an 8 ft wide boarding float with centerline guide piles and 3 ft clear along each side of the piles, there will be up to a 24 inch width available at the center of the float for the width/diameter of the pile, the pile yoke around the pile, and the clearance between the yoke and the pile.

An example would be a 16 inch square pile, 3 inch wide pile yoke frame on both sides of the pile, 1 inch clear on both sides of the pile between the pile and the yoke . . . for a total pile occupied space of 24 inches [16 inch + (3 inch x 2) +(1 inch x 2) = 24 inch]. If smaller piles and narrower pile yokes are provided, the clear width on both sides of the pile will be greater. In any case, the minimum overall width of the boarding float should not be less than 8 ft.

D1.2.2 Articulated Boarding Floats

COMMENTARY:

Articulated boarding floats are essential on launching ramps with variable water levels. As water levels fall, the upper sections of boarding floats will sequentially come to rest on the launching ramp surface, and the hinges between adjacent boarding float sections are necessary to address the angle that exists between the level water surface and the slope of the launching ramp. The location of that angle, or point of articulation, will move up and down the launching ramp with changing water levels.

If individual boarding float sections are too short, say 8 to 10 ft, the string of articulated boarding floats will be “tender” and inordinately over responsive to dynamic loadings from wind, waves, and pedestrian traffic. For example, boarding float sections 10 ft long and 6 ft wide will weigh several hundred pounds. But floating in the water, they can be moved around and tipped up or down very easily. If two large persons are walking down the boarding floats side by side, and two other equally large persons are following about 20 ft behind them, a problem occurs when they pass over the hinge points. There are hinges under both pairs of pedestrians, but there is no live load on the hinge at the mid-point between them. Therefore a shallow “W” profile occurs along the string of boarding floats; the mid-point hinge and the attached float ends go up, and the hinges and attached floats below the people go down. If an emergency is going on including paramedics running down

the floats with heavy equipment in concert with storm conditions that cause waves, the boarding floats can begin to buck and toss in response to variable loading at alternate hinge points, causing an unsafe condition. When the length and total weight of the individual boarding float sections is large in comparison to the size and location of moving loads applied to the floats, most of the above described problem goes away. Boarding floats in the 16 to 20 length range are of sufficient length and dead weight to not be overly responsive to these kinds of loadings, but are still of manageable length and weight for operations personnel to install and remove them seasonally if required, or to perform maintenance and repairs as necessary. In consideration of the above, selection of boarding floats construction materials is important. Ultra-light weight decking, framing and pontoons may work well in still water locations with light pedestrian traffic, but may be totally inadequate to perform safely and properly in most public boat launching facility settings.

D1.3.1 Condition Where 30 inch Maximum Boarding Float Height Applies

COMMENTARY:

The 30 inch maximum allowable height of boarding floats is based on the California Building Code (CBC), Section 1013.1; and the California Code of Industrial Safety Orders, Section 3232 Ramps (g) Guardrails (CCISO). These codes do not specifically address the maximum heights of boarding floats resting on a boat launching ramp. If guardrails were required on boarding floats, it would be in conflict with the nature and use of boarding floats. Boaters must have open and free access to and from their boats tied to the sides of boarding floats. Therefore, an interpretation of existing code requirements is necessary. The 30 inch maximum height has been used in this application since the early 1970s, and has proved to be a reliable safety requirement that is effective and reasonable.

D1.3.1.1 Maximum Overall Height of Boarding Floats

COMMENTARY:

Boarding float height measurements are to be made perpendicular to the launching ramp surface, measured from the top of the peaks of the V-groove ramp surface to the boarding float deck surface. Keep in mind that a 30 inch high boarding float resting on a 12% to 15% launching ramp slope will in fact have a vertical drop of 30.22 to 30.33 inches respectively. In both cases, the true falling height will exceed 30 inches by a fraction of an inch; 0.22 inch (7/32 inch) on a 12% slope, and 0.33 inch (11/32 inch) on a 15% slope. However, the 30 inch maximum float height is meant to be a practical application of common sense. Applied to a boarding float it is easy to measure, fabricate and inspect. If a 30 inch maximum vertical height is applied to a float resting on a 15% slope, the actual maximum height of the float structure could not exceed 29.67 inches. If an owner/operator of a lake had two or more launching ramps of different slopes on the lake, pushed to a ridiculous extreme the collective inventory of boarding floats would not be interchangeable or uniform for the efficiency of operations, maintenance and replacement of the floats. The 30 inch maximum height measured perpendicular to the slope of the launching ramp is a safe, appropriate and reasonable guideline that is easy to apply, measure and maintain.

D1.3.1.2 Boarding Float Height Measurements

COMMENTARY:

Some building permit officials may argue that the 30 inch maximum height should be measured vertically rather than perpendicular to the launching ramp surface. Such an opinion would be based on the fact that a person falling off a boarding float will fall vertically, not perpendicular to the launching ramp. However, a 30 inch high boarding float resting on a 15% grade launching ramp (the maximum allowable slope) has a vertical height measurement of 30.34 inches, only a 0.34 inch increase over the 30 inch perpendicular height.

It is much more practical and accurate to measure between the two parallel lines of the launching ramp surface and the boarding float deck. The top ridges of a V-groove finish on a concrete launching ramp provide a good line of reference to measure from. A person can stand on a short length of lumber to hold it flat against the tops of the V-grooves, and use its lower edge to hold the end of a steel tape to easily check the boarding float height. If attempts are made to measure vertically, it requires a level, plumb bob or other device to establish a vertical line, and depending on exactly where the measurement is taken, the depth of the V-grooves far exceeds the 0.34 inch difference between a perpendicular and a vertical measurement. Common sense dictates measuring boarding float heights perpendicular to the launching ramp surface.

D2.3.2 450 Pounds Live Point Load (LPL)

COMMENTARY:

There are persons with disabilities who, when in their wheelchairs, have a total combined weight of over 800 pounds, and wheelchairs with heavy battery systems are available that weigh over 400 pounds. However, combined LPLs of such magnitudes should not be used for design purposes on boarding floats. The incidence of such large live point loadings on boarding floats will be rare, and accessibility advisory groups have advised against “going overboard” to an extreme when designing recreational boating facilities. To apply an 800# LPL along the edge of a boarding float, and meet the accessibility maximum cross slope requirements, is impossible unless the floats are built inordinately wide to carry the infrequent loading. This would be an irresponsible use of funding, materials and water surface area.

If a boarding float is designed to meet the 450# LPL requirement in D2.3.2, the occasional LPL in excess of this design load will not sink the boarding float, but it will be temporarily out of spec regarding maximum cross slopes. Such large persons in heavy wheelchairs are a special case that must be addressed by the local owners and managers of specific boat launching facilities.

D2.4.1 Freeboard Under Dead Load Only

COMMENTARY:

A maximum freeboard of more than 20 inches may be appropriate at certain locations where the typical trailer boats launched are predominately larger and a higher boarding float freeboard makes boarding and de-boarding easier and safer. Practical upper limits would be 24 inches of freeboard for trailerable boats up to 26 ft long. Keep in mind that a 24 inch freeboard will be a problem for small low gunnel boats frequently used by anglers. There will be a large step into and out of a small boat tied to a 24 inch freeboard dock, problematic for small children and senior citizens.

D2.4.5 Special Conditions

COMMENTARY:

Low-Freeboard Dock = 6 inch to 12 inch freeboard depending on expected use and specific design considerations..

D2.4.4 8 Inch Minimum Freeboard Under DL + ULL + LPL

COMMENTARY:

In most cases an 8 inch freeboard will result in the partial immersion of the fenderboard on the loaded side of the boarding float. However, this is a very short term situation that is dynamic, not static. The fenderboard will come up and out of the water as the boarding float assumes normal freeboard after the LPL has passed. The temporary partial immersion of the fenderboard is no more detrimental to the fenderboard than is repetitive water splash against the boarding float on a windy or stormy day.

D2.6 Deflections On Non-Floating Boarding Floats

COMMENTARY:

The focus here is to avoid inadvertently creating an attractive nuisance. A 20 ft long grounded boarding float that is too “bouncy” can suddenly become a play toy for pedestrians who stop for a little fun. This can be especially problematic when a group of people are walking down the floats together and collectively discover the thrill of bouncing in sync with a flexible boarding float. Such situations can result in injury to the people and damage to the boarding floats.

D3.1.1 Framing Bolts

COMMENTARY:

Galvanized bolts inserted into holes drilled through pressure treated wood will eventually be corroded by the treatment chemicals and the bolt diameters will gradually become smaller. Although this action will take a number of years to occur, the use of larger diameter galvanized bolts will extend their service life, and maintain structural strength longer. To illustrate, the cross sectional area of a 3/8 inch diameter bolt is 2.25 times greater than that of a 1/4 inch bolt. The slight difference in the cost of larger bolts will be well worth it in extended service life.

During the above process, the bolts will become a bit sloppy in the bolt holes and the boarding floats will become somewhat loose. Therefore, annual maintenance should be performed including inspection of a representative sample of the bolts, and tightening of all bolts. This will also address any shrinkage of the wood members that will also cause loosening of the bolted connections.

D3.1.5.2 Boarding Float Support Legs

COMMENTARY:

In most cases, boarding float support legs should be provided only on the down-ramp end of boarding floats for the following reasons:

#1 Where a boarding float is attached to and supported by an abutment, support legs on the upramp end of the first float section are unnecessary. The abutment will carry the entire load.

#2 The presence of support legs on the upramp end of the first boarding float section will cause problems when driftwood and other debris gets caught between the face of the abutment and the lower end of the support legs during periods of high water. As water levels drop, the boarding float gradually rotates on the abutment hinge and comes to rest on the launching ramp. As this happens, a lever action takes place: the debris gets pinched against the abutment face and prevents the support legs from rotating, and the weight of the rotating boarding float gradually (a) crushes the debris, (b) bends the support legs, (c) tears apart the leg/float frame connections, (d) damages the hinge, and/or (e) a combination of the above.



“no-no” float legs next to abutment



support leg adjacent to float hinge

#3 Adjacent sections of boarding floats are connected by full width steel hinges. Relative to the location of the hinge between two adjacent floats, support legs on the lower end of the upramp float will support both float sections joined at the hinge. So, additional support legs on the upper end of the downramp float are unnecessary.

#4 If support legs are provided on the hinge end of both adjoining floats, the same debris leverage problem can occur between the pairs of support legs as described between an abutment and support legs in Reason #2 above.

#5 The most subtle problem that occurs relates to the direction of rotational movement of the bottom end of support legs. As water levels drop, the upper floats progressively come to rest on the launching ramp surface. As each float section comes to rest, the support legs on the lower end rotate vertically around the hinge on the upper end of the float, typically 16 to 20 ft away. This causes the lower support legs to come into perpendicular contact with the ramp surface. However, support legs on the upper end of a boarding float rotate about a hinge that is only 26 to 30 inches nearly vertical above the bottom end of the support legs. When coming to rest on the launching ramp, the lower ends of the support legs approach the ramp surface at a very flat angle, resulting in repetitive scraping actions that impart needless wear and destructive stresses on the support legs, float joints/connections and hinges. This problem is most severe during periods when the water is both calm and dropping. Wave action will cause the floats to rise and fall, thus relieving any catching of the legs on the irregular surface of the concrete V-groove launching ramp surface. Do not underestimate the problems that can result from such an arrangement of support legs on the upramp end of boarding floats.



unnneeded downslope support leg(s)

Do not think this to be a trivial matter. As water levels drop under still water conditions, the maximum degree of scraping of the legs on the ramp surface occurs. With even slight wave action the “coming to rest” boarding float will bob up and down in the water and relieve any scraping stresses that have occurred. However, that same bobbing action will repeatedly subject the support legs to the same scraping stresses over and over again until the boarding float comes to full rest on the launching ramp surface. Literally hundreds of scraping stresses and relief cycles can occur with every change in water level as well as with every boat wake or wind wave that comes in on a boat launching ramp.

It is recommended that support legs not be provided on the upramp end of boarding floats unless such legs are necessary for the seasonal removal and storage of the boarding floats out of the water. Such situations might include launching ramps built in flood zones or on lakes and reservoirs subject to winter freezing.

D3.3.2 Rectangler Pontoon --- Black in Color

COMMENTARY:

The primary reason for black polyethylene pontoons is the high degree of resistance to ultraviolet damage that the black color provides compared to lighter colors. Although flotation pontoons are tucked under boarding float frames and decking, the vertical pontoon walls along the perimeter of a boarding float are still exposed to direct sunlight to some degree as well as to reflected sunlight off the water surface. Lighter color polyethylene is subject to gradual deterioration that results in increasing

brittleness, diminished resistance to impacts, cracking and exposure of the flotation foam inside the pontoons.

A minimum 0.15 inch wall thickness is necessary to provide adequate protection of the interior foam and to ensure the formation of strong pontoon corners. The minimum thickness specified in construction specifications may vary with the type of polyethylene specified, but should never be less than 0.15 inches.

The tops of the tubs must be sealed to prevent water from entering the pontoons and filling any gaps that may exist between the tub walls and the interior foam. Even small amounts of water inside the pontoons can seriously alter the freeboard and balance of the boarding float. The tops of the tubs can be sealed with a thin sheet (10 mil) of polyethylene and then capped with 1/2 inch pressure treated fir plywood. The pontoon assembly can then be securely fastened on all four sides to the bottom side of the float frame. Care must be taken to provide drainage for water that collects on top of the pontoon covers and within the float frame. The bottom corners of the frame blocking can be clipped, or 3/4 inch diameter holes can be drilled in the frame at appropriate points. Fiberglass tubs may also be used but are not readily available, and must be evaluated as to wall thickness, ultraviolet damage resistance, and other factors as required.

D3.3.3 Circular Pipe Pontoon Design Characteristics

COMMENTARY:

Aluminum and galvanized steel pipe have been used for pontoons. However, aluminum pontoons are easily damaged compared with tough polyethylene pontoons, and galvanized pipe pontoons are strong but subject to rusting, particularly in salt water. Neither aluminum nor galvanized steel pontoons are recommended for use on boat launching ramps where floats are repeatedly exposed to bumping and grinding on the launching ramp surface caused by wind waves, boat wakes, tied up boats, pedestrian traffic, tides, and seasonal rising and falling water levels in rivers, lakes and reservoirs.

Although dual wall polyethylene pipe is readily available in a variety of diameters, keep in mind that the overall height of boarding floats (including pontoons) that periodically rest on a launching ramp surface during periods of low water **shall not exceed 30 inches** if such floats are still subject to pedestrian traffic while resting on a launching ramp (**see D1.3 Height Requirements**). The nominal sizes most commonly used for boarding float pontoons have diameters of 12, 15, 18 and 24 inches. However, because of the corrugated nature of the dual wall pipe, the actual gross outside diameters will be 14.1, 17.8, 21.1 and 28.0 inches respectively. Obviously, it would be impossible to use nominal 24 inch diameter pontoons (with a gross diameter of 28 inches) on a boarding float and meet the 30 inch maximum allowable boarding float height.

Taking into consideration that the actual outside diameter of a double-wall

corrugated pontoon will be about 3 inches larger in diameter than the nominal 18 inch diameter, the circular pontoon will actually occupy about 16.7% more width and depth without any increase in buoyancy capacity. This may cause design problems in meeting the freeboard and maximum float height requirements without cutting pontoon saddles into the bottom of the structural frame to gain vertical clearance for the larger diameter pontoons.

Rectangular pontoons essentially have vertical sides and flat bottoms, making the relationship between loading and flotation capacity linear. As rectangular pontoons are submerged under dead and live loading, the **rate** of cumulative buoyancy capacity per vertical inch of submergence is constant, a highly desirable characteristic.

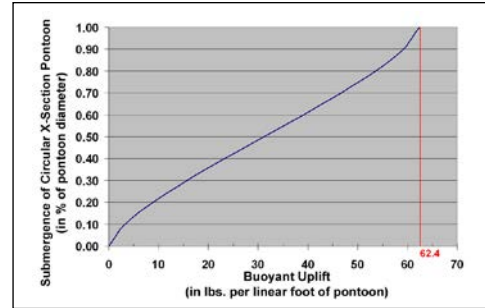

circular pontoon loading curve

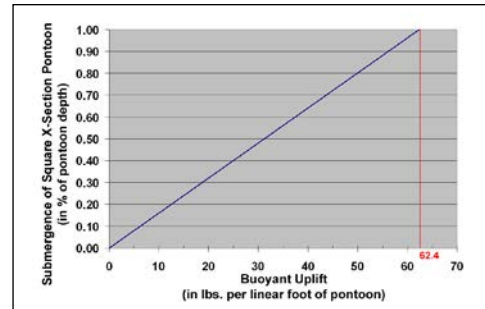

square pontoon loading curve

Circular pipe pontoons have non-linear loading and flotation characteristics. As circular pontoons are submerged under dead and live loading, the **rate** of cumulative buoyancy per “vertical diameter inch” increases until the pontoon is submerged to its center, and then decreases as it approaches full submergence.

- Rectangular pontoons are more efficient than circular pipe pontoons from the standpoint of providing more buoyancy per square foot of area occupied on the bottom of a boarding float frame. Shallower pontoons can be used that will more easily meet buoyancy, freeboard and maximum float height requirements.
- Where boarding floats come to rest on the surface of a launching ramp during low tides or seasonal low water, the bottom surfaces of both tub and pipe pontoons must be protected against abrasion and puncture. The floats should come to rest on the legs, not on the flotation pontoons. The boarding float legs will maintain suitable clearance under the pontoons to protect against the launching ramp surface, small rocks, gravel and debris.

ILLUSTRATION: Comparing an 18 inch x 18 inch square cross section pontoon with an 18 inch diameter circular pontoon theoretically inscribed inside the 18 inch x 18 inch square yields the following results:

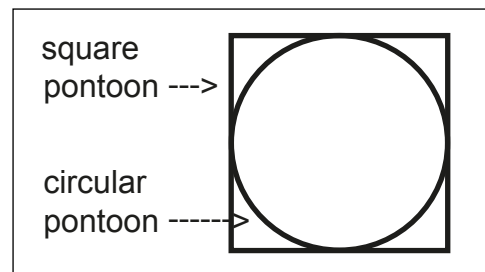

superimposed vertical x-sections of square and circular pontoons

| <u>Pontoon Type</u> | <u>Cross Section Area</u> |
|--------------------------|---------------------------|
| 18 inch x 18 inch square | 324 inches ² |
| 18 inch diameter | 254 inches ² |

☛ Per linear foot of pontoon length, the 18 inch diameter circular pontoon has only 78% of the buoyant capacity of the 18 inch x 18 inch square pontoon.

☛ Per linear foot of pontoon length, the 18 inch x 18 inch rectangular pontoon has 128% greater buoyancy capacity than the 18 inch diameter circular pontoon.

☛ Per linear foot of pontoon length, both “theoretical” pontoons occupy exactly the same space on the bottom of a boarding float frame.

D3.3.4 Pontoon Flotation Foam

COMMENTARY:

Flotation foam should be purchased from a reputable manufacturer with a positive history of supplying marine grade flotation foam to the recreational boating industry.

Flotation foam should meet the following minimum requirements:

- density of 1 to 2 pounds per cubic foot;
- 2% maximum water absorption per cubic foot;
- regrind not to exceed 15% by volume;
- foam will not support growth of bacteria and/or fungus; and
- foam is free of significant voids that can fill with water.

Flotation foam is typically polystyrene or polyurethane, and is available in two forms:

(1) Closed cell extruded polystyrene is rigid and resistant to water absorption. It lends itself to being cut and shaped for placement inside rigid pontoon shells. Closed cell polyurethane foam is made by mixing two components and pouring the mixture into a form or closed pontoon shell. It expands to several times its original volume and if correctly measured will completely fill a pontoon shell. Denser than polystyrene foam, it is also more resistant to gasoline and solvent melting. However, the quality control of mixing, pouring and foaming the pontoons is highly critical, being greatly influenced by temperature, mixing time and other variables. Also, as the components expand and the foam is created, polyurethane will often fold over upon itself and create sizable voids which are difficult to detect. These voids will sometimes fill with water over an extended period of time and cause serious flotation problems. Using polyurethane foam inside enclosed pontoon shells is not recommended unless foaming is performed at a plant operated under controlled conditions as per foam manufacturer’s recommendations.

(2) Open cell expanded polystyrene (EPS) is manufactured by steam expansion of polystyrene pellets inside a mold or closed vessel. Commonly called bead board, it can be steam expanded inside an enclosed pontoon shell, or cut to size and inserted into open-top pontoon tubs or open-end pipe pontoons. It is the most commonly used foam flotation material inside rigid pontoon shells.

Using totally enclosed rigid pontoon shells such as rotocast polyethylene pontoons, the flotation foam must be foamed in place inside the pontoon. Where open shell pontoons are used, such as tubs and circular pipes with open ends, it is recommended that the flotation foam be cut to size and inserted to ensure a snug fit absent voids that can gradually fill with water and diminish the buoyant capacity..

Exposed foam must not be used for boarding float pontoons. Exposed open cell expanded polystyrene, commonly known as bead board, is fragile, easily damaged and will dissolve upon contact with hydrocarbons such as gasoline and oil. Exposed polyurethane is more durable than open cell expanded polystyrene, but is still subject to mechanical wear and damage from floating debris, boats and ultraviolet exposure. Both kinds of foam are subject to damage from gnawing and nesting rodents around waterfront facilities. Individual beads of open cell expanded polystyrene can break away from foam pontoon billets and be ingested, resulting in deformation and/or death of fish and wildlife.

D3.4.2 Fender Boards

COMMENTARY:

Fender boards integral to the structural frame are typically bolted to cross members in such a way that warping and curling of fender boards is prevented. They usually stay stable, straight and true. Additionally, there is a cost savings in original construction as they do double duty as structural members and as fender boards.

However, when they are damaged and have to be replaced, it requires “major surgery” that may not be prudent or possible to do in the field. Removal of integral fender boards will usually affect the decking, cross bracing and pontoons as the structural skeleton is violated. Twisting, sagging and deformation of the float can occur if not properly supported and braced during replacement, especially if fender boards along both sides of boarding floats are removed at the same time.



circular pontoons to be foam filled

Sacrificial fender boards are typically bolted, screwed or nailed to the structural frame, and by their nature are prone to warping and curling under the influence of thermal expansion and contraction, changes in seasonal moisture content, and inappropriate bolt, screw and/or nail pattern attachment. However, they have the great advantage of relative ease of removal and replacement which can usually be done in the field by maintenance staff. Additionally, the fastening and refastening of

bumper strips will be invasive to the sacrificial fenderboard, and not to the structural frame. In most cases, this is the design option to be utilized, especially in urban areas with high use and heavy wear on the boarding floats.

D4.3.2 Maximum Water Level Fluctuation for Articulated Boarding Floats

COMMENTARY:

The acceptable range of boat launching ramp slopes is 12 to 15 percent. A 12% slope has a vertical drop of 12 ft over a 100 ft horizontal length, a horizontal-to-vertical ratio of 8.33 to 1.00. The ratio on a 15% launching ramp is 6.67 to 1.00. Therefore, on a 12% launching ramp with a 16 ft water drawdown, an articulated boarding float system would have to be 133 ft long (8.33 X 16 ft). On a 15% launching ramp the floats would be somewhat shorter at a required length of 107 ft (6.67 X 16 ft). Even on the 15% slope ramp, it would require seven 16 ft float sections, or six 20 ft float sections to serve the 16 ft drawdown. The situation is more severe on the 12% launching ramp, requiring nine 16 ft float sections or seven 20 ft float sections for a 16 ft drawdown. Anything beyond this is impracticable for boaters to use and unreasonably increases operational, maintenance and repair costs.

D4.4.2 Cable Guided Boarding Floats with Hinged Sections

COMMENTARY:

The hinges allow the boarding floats to generally conform to the slope of the launching ramp during critical periods when the upper end of the floats catches on a stop block provided to arrest further downward movement. As water levels continue to drop, the stop block controls the rotation of the floats as they gradually come to full rest on the surface of the launching ramp. Without the hinge, or hinges, the long float structure would temporarily become a bridge spanning between the stop block and the supporting flotation pontoons out on the extreme end of the boarding floats. The extreme end would probably go underwater until enough pontoon buoyant uplift was active to support approximately 50% of the dead weight of the boarding float. This would also result in the middle of the float being suspended in the air as a bridge, a structural loading situation that boarding float systems are not typically designed to carry. The hinge(s) is essential to the longevity and functioning of the boarding float system.

D4.4.3 Anchorage of Boarding Float Guidance Cables

COMMENTARY:

Guidance cables can be anchored at the top and bottom of a launching ramp utilizing cable boxes and blockouts as follows:

- At the top of the launching ramp, form a blockout wide and long enough to install and maintain a heavy duty vertically anchored eye bolt or steel anchor plate, a large turnbuckle, guidance cable folded double and six cable clamps. A cable thimble must be used in the eye bolt or anchor plate to protect the guide cable.

- ☛ At the top of the launching ramp, a galvanized steel cable box with the following features can be cast into the concrete launching ramp slab:
 - 6 to 8 ft long, 12 inches wide;
 - 1/2 inch minimum thick bottom;
 - 3/8 inch minimum thick walls;
 - steel angle frame around top of box;
 - taper bottom depth over length of box to provide downhill drainage;
 - removable box cover plate--
 - with angle frame along all four sides;
 - sized to fit into cable box flush with ramp surface;
 - heavy enough to discourage removal; and
 - theft and vandal resistant.
 - 1/2 inch thick vertical cable anchor plate--
 - welded to bottom of box;
 - drilled to loosely receive turnbuckle eye or cable thimble;
 - heavy duty 4 ft long turn buckle for tightening cable;
 - downramp end slot in grating for cable exit;
 - box frame and grating to be flush with surface of launching ramp;
 - box sized to hold, operate and protect all cable anchor hardware.

- ☛ At the bottom of the launching ramp a concrete blockout can be provided in the launching ramp slab large enough for a heavy galvanized steel eye anchored in the concrete and attached to reinforcing steel not less than 4 inches below the concrete surface. Both the upper and lower ends of the blockout should be gradually tapered: the bottom end to allow for drainage and flushing out of the blockout, and the upper end to receive the lower end of the wire rope cable including a thimble and at least three wire rope clips. All hardware in the blockout should be flush with or below the launching ramp surface.

D4.4.4 Cable Guided Boarding Float Systems on Curved Launching Ramps

COMMENTARY:

Cable guided floats have been used on curved launching ramps by providing blockouts in the launching ramp with “open hooks” to which the cable can be forced down into the blockout and hooked under the open hook. When the cable is tightened the hook points keep the cable generally aligned with the curve of the launching ramp. However, to enable the boarding float to move up and down the ramp, the float must be tied to the cable with pigtail cables fitted with hardware that can be opened and closed for attachment around the guidance cable. This necessitates operational staff going into the water to detach and reattach the pigtail to the main cable at each point where the guidance cable is stitched down to the launching ramp. It is a system that will work reasonable well during a summer boating season if staff is careful to attend to the float as necessary. When water is rising and the pigtail is not moved up above each successive hook point, the pigtail will hang up on a hook point and will gradually pull the boarding float under water until it either breaks loose or is cut free by a diver. Such a submerged float can be

very dangerous to free up because of the very explosive nature of the float surfacing after being cut loose. Such situations must be avoided. This type of boarding float system is not advised unless no other alternative will work at a given site, and the staff is trained and closely supervised to ensure the float and cable guidance system is operated correctly and safely.

D4.5 Single-Rail Guided Boarding Floats

COMMENTARY:

It is critical that the rails be designed and fabricated such that the rail joints are straight and true, and do not provide any misalignments on which the trolley can catch and get hung up. Also the rail joint design must ensure continued alignment of the rails during thermal expansion and contraction that can vary from 100+ degrees on hot summer afternoons down to sub-zero temperatures on cold winter nights. The length of a steel rail system several hundred feet long can expand or contract several inches under these temperature extremes. Consequently, the joints, connections and support brackets must be designed to allow for such thermal movement and still maintain alignment, strength and functional reliability.

D4.6.1 Dual-Rail Guided Boarding Float

COMMENTARY:

The dual-rail system will function well on both straight and moderately curved launching ramps, but will not reliably negotiate a curve with less than a 300 ft radius. For large drawdown situations, the dual-rail system is the most stable and reliable self-adjusting system available to date. Its major drawback is that it is also the most expensive. It should also be noted that this float system will exceed 30 inch in height when resting on the launching ramp during periods of low water. The rail will be about 11 inches high and the float will be an additional 28 inches, making the overall height from the top of the float deck to the launching ramp surface approximately 39 inches. However, this does not suggest that handrails are necessary since this type of float will be out of service and not used by boaters when it is resting on the launching ramp. It will not provide pedestrian access at such times.

D5.1.3 Location of Boarding Float Abutments

COMMENTARY:

In most cases the vertical curve will be in the maneuvering apron, and the head of the ramp will be a foot or two above design high water. This will allow the abutment to be located at the head of the ramp, and fully on the launching ramp slope rather than in a position straddling the apron, vertical curve and the head of ramp, a situation that is messy to design, difficult to build, and impractical at best. Such cases usually occur where design high water is nearly the same elevation as the parking lot, maneuvering apron, vertical curve and the head of the ramp, a situation in which all the various components get squeezed together.

In cases where the terrain is steep, and parking areas and access roads are located well above design high water, the actual launching ramp may sometimes

begin well above design high water to facilitate building the vertical curve and vehicle maneuvering area. In such cases the abutment should not be located at the head of the ramp but rather down the ramp just above design high water. Otherwise additional sections of boarding floats will be required that add nothing to the functioning of the launching ramp, waste construction funds, and increase maintenance costs, a situation to be avoided.

D5.1.9 Abutment Face Characteristics

COMMENTARY:

The depth of boarding float structural frames is typically 10 to 14 inches. At high water the vertical face of the upper end of a boarding float hinged to an abutment will be essentially parallel to the abutment face. However, as water levels drop, the float will rotate on the abutment hinge and the lower edge of the boarding float frame will rotate toward the abutment face. Constructing the abutment face, below the hinge, perpendicular to the launching ramp surface will ensure that the boarding float frame will never rotate into the abutment face, a situation that can result in serious damage to the hinge and boarding float. Even if the boarding float comes to full rest on the launching ramp surface, the vertical face of the float frame will never rotate beyond the point of being parallel to the face of the abutment.

D6.2.1 Minimum Guide Pile Cutoff Elevation

COMMENTARY:

The provision of not less than 6 ft of pile above the boarding float dock may seem excessive considering the installed cost of piles as well as the height and appearance of such piles at low water. However, there are other factors to be considered. Piles with top elevations only 3 to 4 ft above the dock at design high water become targets for vandals and pranksters. Such guide piles are typically capped with white fiberglass cone-shaped pile caps secured to the tops of concrete and/or steel pipe piles. The pile caps can be frequent objects of theft if access to the top of the piles is too easy. And when pile caps are removed from steel pipe piles, the hollow piles will be used as trash and debris receptacles and nesting sites for flying insects such as bees. Therefore, from an operational standpoint, the provision of a few feet of extra pile length will help address these problems and eliminate what might be considered an attractive nuisance.

D7.3.3 Interior Pile Yokes – Disadvantage #2

COMMENTARY:

Some recently built boarding floats have been equipped with metal pile yoke covers that prevent people from stepping or falling into the yokes, but curbs are still required and possibilities of tripping will remain. However, such curbs around pile yokes are normal to boarding float design, are not considered to be serious threats to life and limb, and boaters are typically very aware of their presence as they are of boat cleats, rings and other common float hardware. In some cases where floats are on an accessible route, raised curbs 4 inches high are permitted by federal accessibility federal accessibility guidelines at certain locations along the edge of floats. So pile

yoke curbs are not out of the ordinary and not any more hazardous than a curb along a walkway.

Also keep in mind the fact that the cross sectional area of a pile yoke opening will be significantly filled with a guide pile, greatly diminishing the possibility of someone falling into or becoming wedged in a pile yoke. This is particularly evident in pile yokes on boarding floats that only move vertically up and down the piles with changing water levels. The pile yokes would be square, and the standard clearance between the pile and the four sides of the yoke is 1 inch on each side. If a boarding float is pushed up against the pile on one side, there would be a maximum 2 inch clear opening between the pile face and the yoke on the opposite side.

Where boarding floats are hinged to abutments, they rise and fall with changing water levels, rotate about the abutment, and a lateral movement of the floats relative to the fixed position of the piles occurs. The further the pile from the abutment, the greater the lateral movement of the pile yoke relative to the pile. This dynamic movement requires that the pile yokes be rectangular in shape with the long dimension parallel to the length of the boarding floats. At high water levels the shoreward end of a pile yoke will be near the shoreward face of the guide pile, but as water levels drop and float rotation occurs, the yoke will gradually drop vertically as well as slide along the pile horizontally, and the yoke openings will increase and diminish accordingly.

D7.4.3 UHMW Pile Yoke Rollers

COMMENTARY:

This special polymer material is self lubricating, incredibly tough, highly resistant to abrasion, non corrosive, has a low coefficient of friction, functions well at both high and low temperatures and is unaffected by various marine environments including salt water exposure. UHMW roller material is extruded in a range of diameters in lengths up to 10 ft. Individual rollers are then cut to length. Pile yoke rollers are typically 3 to 5 inches in diameter and 4 to 6 inches long. Although black is preferred for ultraviolet light protection, a variety of colors is available.

D7.4.6 Pile Yoke Dimensions

COMMENTARY:

Replacement of roller assemblies and/or rollers will not be a problem if the assemblies are vertically bolted to the pile yoke frames, making them easily accessible above the deck for maintenance as required.

Maintenance and replacement of rub strips is more difficult because of their position down in the yoke openings between the piles and the pile yoke frames. The standard clearance between piles and rub strips is only 1 inch. Even with a boarding float pile yoke pushed hard against a pile on one side the maximum clearance on the other side will be only 2 inches, insufficient for bolt removal and replacement. Consequently, horizontal bolts must be located at the ends of the rub strips to

provide adequate clearance along the side of piles to remove and replace the bolts. In such situations round piles are more forgiving and allow more open space in the pile yokes than square piles.

Based on the above matters, consideration should be given to either vertically bolting the entire pile yoke frame to the boarding float structural frame, or vertically bolting individual rub strips to the yoke frame. In either case the connecting bolts will be vertical and easily removed and reinstalled as required.

WARNING: When maintaining pile yokes, the insertion of hands and tools into the open spaces between yokes and piles can be dangerous. A sudden lateral movement of a boarding float can create a vice-like situation that can trap and crush whatever is caught in the yoke. A tool trapped in a person's hand in such a situation can add to the injury. Therefore, pile yokes must be blocked or otherwise stabilized to arrest movement between a pile and a pile yoke while maintenance work is being done. A wood or metal device can be designed and fabricated for vertical insertion into the pile yoke that will accomplish stabilization and still allow adequate access for doing the necessary work.

D7.5.3 Recommended Pile Yoke Clearances

COMMENTARY:

The recommended 1 inch side clearance is neither a maximum nor a minimum. If less than 1 inch on each side, 2 inches total, it will be difficult to drive piles within vertical alignment specifications and still have the yokes freely ride up and down the piles without binding at certain water levels. If more than 2 inches total is provided, the horizontal constraint on the boarding floats will be too loose and will result in unnecessary stresses on the abutment and boarding float hinges.

For reference, consider the ends of a rectangular pile yoke to be “near end” and “far end” relative to the abutment on shore. The recommended 4 inch minimum clearance at each end provides a margin of error to help ensure that the ends of a pile yoke never come into contact with the pile.

- At high water the near end of the pile yoke is essentially square with and approximately 4 inches from the face of the pile.
- At low water when a boarding float assumes the slope of the launching ramp, the far end of the pile yoke is closest to the pile and at the ramp slope angle to it. Depending on the design and depth of a pile yoke, this angled position of the yoke results in the lower edge of the yoke being closer to the pile than the upper edge.

EXAMPLE: Heavy duty wood frame boarding floats are sometimes built with interior pile yokes consisting of the frame structure itself, often 12 inches in depth. When resting on a 15% launching ramp, the top and bottom edges of both ends of the 12 inch deep pile yoke are offset by 1.8 inches, nearly half of the recommended 4 inch end clearance. If this factor is not taken into consideration on steeper

launching ramps with deep frame pile yokes, an assumed 4 inch clearance at deck level may in fact be only about 2 inches at the bottom of the yoke frame.

Extreme care must be taken to precisely determine the design location of each guide pile, and later the exact location in the field after each pile has been driven. The same care must be exercised in properly sizing each pile yoke and its location on a boarding float at precisely the correct location. All of this must be done in relationship with the horizontal distance from an abutment hinge to the centerline of each guide pile. It must be kept in mind that the pile yoke moves with the boarding float, but the pile does not. If a tug-of-war occurs during changing water levels, the pile will win.

D7.5.4 Square Pile Yokes

COMMENTARY:

Examples of launching ramp floats that are not connected to abutments and that do not come to rest on a launching ramp slope include floats that never ground out and are accessible via a gangway, and courtesy floats provided near a boat launching ramp but accessible only by boat.

Courtesy floats are particularly useful at high traffic launching ramps where it is necessary to get launched boats away from the launching ramp and boarding floats so other boaters can launch or retrieve their boats. A courtesy dock provides a temporary tie-up away from the launching ramp where boaters can secure gear, put on life jackets and make final preparations to get underway. Also, incoming boaters can drop someone off at the end of a boarding float to retrieve their vehicle/trailer, and then temporarily tie up to a courtesy float while waiting their return and for an available launching lane for boat retrieval.

D8.3.3.3 Edge Protection on Leading Edge of Gangplanks

COMMENTARY:

Since a gangplank will be at or near level most of the time, there will always be an angle of 8.33 degrees to 6.67 degrees between a gangplank and launching ramps with 12% to 15% slopes. Therefore, a slightly wedge shaped UHMW strip approximately 3/4 to 1 inch in thickness and 6 inches wide can be machined and screwed to the underside of the gangplank leading edge. The wear strip will protect both the gangplank and the launching ramp surface, and can easily be inspected and replaced as required. It will also help guard against a gangplank getting caught on the launching ramp surface under rising water conditions, a situation that can cause considerable damage to the gangplank.

D9.4.2.2 Maximum Gangway Handrail Heights

COMMENTARY:

36.0 inches is the maximum handrail height for gangways that do not exceed a maximum slope of 3:1, measured perpendicular to the gangway deck surface to the top of the handrails. As a gangway (and the attached handrails) rotates vertically with changing water levels, the perpendicular height of the handrails remains constant.

However, as seen in Table D9.4.2.3, the vertical height from any point on the top of the handrail to the gangway deck progressively increases as the gangway slope increases. At zero slope, a 36.0 inch handrail height is both the perpendicular dimension to the deck and the vertical dimension from the deck. But at a slope of 3:1 the vertical dimension increases from 36.0 to 37.9 inches, and at a slope of 2½:1 it increases to 38.8 inches, exceeding the maximum allowable height of 38.0 inches. Even worse, a 38 inch high handrail height at zero slope increases to 40.1 inches at a 3:1 slope, and 40.9 inches at a 2½:1 slope, both well above the 38 inch maximum allowable. Therefore, D9.4.2.2 and Table D9.4.2.3 indicate a maximum gangway handrail height of 36.0 inches for gangways that do not exceed a slope of 3:1, and 35¼ inches for gangways that do not exceed a slope of 2½:1.

Table D9.4.2.2

| Perpendicular Height from Top of Handrail to Gangway Deck | | | | | | | | | | |
|--|---|------|------|-------|------|------|------|------|------|------|
| Slope [H to V] ▼ | 34.0 | 34.5 | 35.0 | 35.25 | 35.5 | 36.0 | 36.5 | 37.0 | 37.5 | 38.0 |
| | Vertical Height from Top of Handrail to Gangway Deck | | | | | | | | | |
| 3:1 | 35.8 | 36.4 | 36.9 | 37.2 | 37.4 | 37.9 | 38.5 | 39.0 | 39.5 | 40.1 |
| 2½ :1 | 36.6 | 37.2 | 37.7 | 38.0 | 38.2 | 38.8 | 39.3 | 39.9 | 40.4 | 40.9 |

D9.9.1.1 and D9.9.1.2 90 degree Intersections of Boarding Floats and Gangways
COMMENTARY:

Where “L” or “T” shaped boarding float/gangway combinations are used, typical 8 ft (96 inches) wide boarding float widths will be too narrow to accommodate:

- 48 and 60 inch clear space between boarding floats and transition plates;
- the typical 18 to 30 inch widths of transition plates;
- the extra float width needed for lateral movement of the gangway rollers on the boarding floats between high and low water levels; and
- a healthy 12 inch margin of error on the backside of gangway rollers.

All of this can easily add up to 10 or 12 ft wide boarding floats, depending on local water level fluctuations and wave characteristics. So, rather than making a wider float, provide a dedicated “gangway flotation unit” that attaches to, or is built into the boarding float at the location where the gangway lands on the float. Gangways will usually require a dedicated float platform at least 10 ft wide and 12 ft in length, depending on the length and weight of the gangway. Such a flotation unit should be hinged to the boarding float providing even deck levels and freeboard. Make sure the hinge barrel and pin are reasonably tight to avoid wearing movement, and are easy to lubricate as necessary. The boarding float itself should not be depended upon to support the gangway dead and live loads.

Appendix A: Commentary – Section E

E1.1.2 Maximize the Number of Vehicle/Trailer Parking Spaces

COMMENTARY:

A 40 ft long vehicle/trailer space can be divided with a dashed paint stripe to create two end-to-end 20-ft single vehicle spaces. However, this can cause problems with efficient use of the boat launching facility parking areas, and confusion for both individual vehicle and vehicle/trailer drivers. If someone parks their vehicle/trailer rig in a double individual vehicle space, local parking enforcement officers may very well give that person a parking ticket for parking across the dashed paint stripe that delineates the divided vehicle/trailer parking space. Also, single vehicles may be randomly parked in vehicle/trailer spaces, eating up available space for vehicle/trailer rigs. It is not unlike an individual person occupying a two-seat table in a restaurant during busy hours.

E1.1.3 Single Vehicle, Single-Trailer and Trailer-Only Parking Spaces

COMMENTARY:

Some sites may not be suitable for 40 ft long vehicle/trailer parking spaces. An example would be a long slender parcel not wide enough for driveways and a row of vehicle/trailer parking spaces. Single spaces for vehicles and un-hitched trailers might be a reasonable alternative. However, the security of the un-hitched trailers is always an issue. Therefore, where single-trailer spaces are provided, steel pipe hitching posts with 2 inch inside diameter steel rings or eyes should be installed for securing the trailers with chains and locks. If space permits, a radial pattern of trailer parking spaces can sometimes be utilized. Several trailers can be parked radially around a common steel hitching post fitted with an appropriate number of locking rings or eyes. Such steel hitching posts should be made of 4 to 6 inch diameter galvanized steel pipe set vertically in not less than 24 to 30 inches of concrete. The tops of the hitching posts must be covered with threaded caps or welded dome covers to prevent the collection of trash, debris and insects.

E1.1.4 Pull-Through Vehicle/Trailer Parking Spaces

COMMENTARY:

Many boat launching facility owners and operators have witnessed the increased number of minor vehicle/trailer accidents that occur where backing is required to exit a vehicle/trailer parking space. The potential for such “fender benders” goes up during summer weekends and holidays when traffic volume increases and the pressures of dealing with both vehicles and pedestrians may cause inattention and impatience on the part of both the drivers and pedestrians.

E1.1.5 Single-Vehicle Parking Spaces at End of Row of Diagonal Parking

COMMENTARY:

For example, rows of 45 degree and 60 degree diagonal parking spaces will always have short spaces at the beginning and end of every row of parking. These short spaces are not long enough to provide the length required for a vehicle and trailer. Also, the very tight turning radii required to either enter or exit such spaces at the ends of rows is difficult and sometimes impossible without some backing up to align with the parking space or the parking facility driveways.

E1.1.6 Extra Long Vehicle/Trailer Parking Spaces

COMMENTARY:

In recent years, particularly at coastal locations in Southern California, vehicle/trailer parking spaces up to 55 ft long have been provided to accommodate longer trailer boats and bigger towing vehicles. The number and location of these longer spaces will be determined by site factors and the actual demand. When attempting to incorporate longer parking spaces into a parking layout, the turning radii required for entering and exiting such longer spaces is greater than for the typical 40 ft spaces, and necessitates wider driveways and greater turning radius roadways at the ends of the rows of parking spaces. When dealing with longer vehicle/trailer parking spaces, it is even more important to provide pull-through parking spaces.

E1.1.7 Non-Boating Activity Parking Demand

COMMENTARY:

Parking facilities for other interests and activities that sometimes exist near a boat launching facility must be provided by the owners/operators of those interests and activities independent from the launching facility parking. This is a common problem in urban settings where a boat launching facility operates near beaches, parks, marinas, bus stops, restaurants, shops, and other commercial operations. The level of parking required for boat launching facilities is not based on high demand summer holiday weekends; nor is it based on low use days in winter. Therefore, the reasonable level of parking required is gauged to address the parking demands that will occur throughout the year, under a variety of demand situations, in concert with but separate from other interests and activities that require various levels of parking capacity.

E1.1.8 Planter Islands and Planter Strips in Parking Areas

COMMENTARY:

In some urban areas, local building permits require various levels of shade to be established over a specified period of time. For example, the city of Sacramento, CA has a building permit requirement that at 12:00 noon on July 1st, 25 years after completion of an outside parking area, 50% of the parking area must be in shade. This requirement has a bearing on the number, location and type of trees planted. The utilization of parking area islands at the ends of rows of parking spaces helps meet such permit requirements. It also provides much needed shade for vehicles, trailers and equipment that is subject to ultraviolet damage during hot summer days.

E1.2 Locate Parking Near Head of Ramp

COMMENTARY:

This is not an arbitrary matter. A boat launching facility is often planned, constructed and operated near other land use activities, resulting in competition for the location and size of land areas for parking. If priorities are not established for the provision of suitable levels and reasonable location of boat launch ramp parking, trailer boaters will not be well served, and the facilities will not be reasonable, appropriately convenient and safe for public use.

E1.3.1 Number of Parking Spaces per Launching Lane

COMMENTARY:

The 20-30 vehicle/trailer spaces per launching lane is a good rule of thumb to use, absent more definitive information in planning a boat launching facility. In high use urban locations, the ratio may have to be raised to 50 vehicle/trailer spaces per launching lane, provided the land area is available. In these urban settings, multiple types of boating activity can occur that includes fishing, water skiing, cruising and sailing. The duration of the boating activities will vary with the type of activity, the average age of the participants, the time of day the activity typically occurs, and the season. Fishing is frequently an early morning and late afternoon boating activity while water skiing tends to be a mid-day activity when air temperatures are warmer. So there can be a turnover of the parking spaces as the nature of the various boating activities occurs and ends throughout a local boating season.

In rural locations where boating typically occurs on lakes and reservoirs, the duration of boating activities may be much longer because of longer travel distances on the water to get to favorite ski areas, fishing holes, etc. However, if the travel distance from a population center is great or difficult, it may be appropriate to lower the parking ratio down to 15 vehicle/trailer spaces per launching lane. The acquisition of objective reliable data that reveals where the boaters will come from, what they will be doing and how long they will stay is necessary to the process of planning and operating a public boat launching facility, urban or rural.

On small remote lakes and reservoirs of 50 surface acres or less, it may be entirely reasonable to provide a single-lane launching ramp with only 5-10 vehicle/trailer parking spaces. In such cases, non-paved overflow parking areas may be available for use on holidays as required.

E1.4.1 Vehicle/Trailer Spaces

COMMENTARY:

These vehicle/trailer parking space dimensions are time tested, well established, and should not be reduced. Trailers can legally be up to 102 inches wide (8 ft 6 inches). Parked in a 120 inch wide (10 ft) parking space, the trailer will have only 9 inches clearance on each side of its fenders **IF** the trailer is parked exactly in the center of the parking space. In cases where two maximum width trailers are parked in the center of adjacent parking spaces, the actual clearance between the trailer's fenders would be only 18 inches, not exactly overkill when considering the length of most vehicle/trailer rigs, the potential sizes of the towing vehicles, obstructions to driver's vision (boats on trailers, camper shells on trucks, equipment and bags piled high inside of vehicles, etc.), and the steering maneuvers necessary to safely enter and exit the parking spaces.

E1.4.2 Single-Vehicle Spaces

COMMENTARY:

The minimum width of a single-vehicle space is one foot narrower than a vehicle/trailer space because of the absence of the trailer. In some cases there will be a temptation to reduce the width of single-vehicle spaces down to 8 ft to squeeze in a few more parking spaces. This works in a variety of parking situations, but is not advisable in a boat launching facility parking area. Single vehicles are usually present in conjunction with one or more other vehicles pulling boat trailers, and often carry equipment, boating gear, large canvas bags and other items that require fully opened doors for loading and unloading. 8 ft wide parking spaces are too narrow to meet the functional needs of single vehicles parked in a boat-trailer parking area.

E1.5 Parking Lot Finish Grades

COMMENTARY:

A 2% minimum finished slope on AC paving is a recognized industry standard for realistically achieving a paved surface that will drain properly in a timely manner. It is difficult for paving contractors to accurately achieve flatter slopes that do not have "bird baths", low spots that temporarily pond irrigation overflow and rain water. Additionally, a finished slope of less than 2% provides very little forgiveness for occasional localized settlements of the base and sub-base material below the AC paving which can result in the creation of bird baths. The presence of bird baths causes wet shoes and feet; inconvenience to boaters; flaking of parking space paint stripes; and discoloration and accelerated deterioration of the AC paving.

A 5% maximum slope is a comfortable and realistic upper limit under most circumstances. Obviously 5% slopes drain very well, and they are comfortable for most people to walk on and use in exiting and entering their parked vehicles.

On rather steep sites, it may be impossible to provide a parking facility with all slopes of less than 5%. However, as the slope gets steeper, user problems develop. A vehicle parked sideways to a steep slope will have an uphill door on one side and a downhill door on the other. The uphill door may be too heavy for the driver or passenger to open without great effort, and the downhill door may fly open when unlatched and bang into an adjacent vehicle or pedestrian passing by. There have actually been cases where senior citizens have opened downhill doors while firmly grasping the inside door handle, and have been yanked out of their vehicles and onto the pavement. Thus the 10% maximum slope, and the recommended 5% maximum slope for parking facilities.

E2.1.5 Wheel Stops and Curbs in Parking Spaces

COMMENTARY:

Typical parking wheel stops are concrete or recycled plastic, and range from 4 to 6 inches in height. Many newer vehicles as well as a growing number of modified older vehicles have special ground effects attachments, air dams, fog/driving lights, gravel shields and other accessories that reduce ground clearance beneath the vehicles. If the front end of such a vehicle passes over a 6 inch or higher wheel stop, the vehicle will probably be damaged. Therefore, it is recommended that wheel stops and curbs not exceed 4 inches in height where they are provided to limit the forward movement of a vehicle being parked in a space that fronts on an accessible route. The intent is to maintain the clear width of the accessible route by preventing intrusion of the front ends of parking vehicles.

E2.2.3 Minimum Number of Van-Accessible Parking Spaces

COMMENTARY:

Under the **2010 ADA Standards** and the **2013 California Building Code (CBC)**, for every six or fraction of six accessible parking spaces ... at least one shall be van-accessible. The ratio of van-accessible parking spaces to accessible parking spaces has been increased from 1 in 8 ... to 1 in 6. The “increase” is not in the number of accessible parking spaces, but in the required number of van-accessible parking spaces.

Example: Look back at Table E2.2.1 in Section E2.2.1.

A parking lot with 210 parking spaces must have a minimum of 7 accessible parking spaces. And for every six or fraction of six accessible parking spaces, at least one van-accessible parking space must be provided. Therefore, the parking lot with 210 parking spaces would have to have at least 7 accessible spaces, 2 of which (1 for every 6, or fraction of 6) would be required to be van-accessible. So, the increase from 1 in 8 to 1 in 6, is the increase in van-accessible parking spaces.

Take one last look at Table E2.2.1 in Section E2.2.1. Note that if the ratio was still 1 in 8, the minimum number of van-accessible parking spaces in the 210 space parking lot would be 1, and would not go up to 2 until the total number of parking

spaces was in the range of 401-500 spaces. But, the 1 in 6 ratio boots it up to a minimum of 2 van-accessible parking spaces within the range of 201-300 parking spaces.

E2.2.4.1 Non-Reserved Accessible Parking Spaces in Small Parking Lots

COMMENTARY:

A van-accessible parking space and access aisle in a parking lot with less than five parking spaces has to be striped to delineate the required minimum dimensions of both the parking space and the access aisle. However, the normal requirements for accessibility signs and pavement markings are not required, and should not be provided. Otherwise, the public will assume the parking space is reserved for use by persons with disabilities only. Accessible parking spaces paved with gravel do not have to be paint striped.

E2.3 Table / Position of Access Aisles in Duplex Vehicle/Trailer Parking Spaces

COMMENTARY:

In a duplex vehicle/trailer parking space, the access aisle does not have to be on the driver side of the vehicle. To impose such a requirement would defeat the intent of allowing a common access aisle to serve two accessible parking spaces. If both parking spaces in a duplex vehicle/trailer parking space are vacant, a vehicle driver has the option to park with the access aisle on either the driver side or the passenger side of the vehicle. Since in actual application of these guidelines we do not know if a person with a disability will be the driver or a passenger, duplex parking spaces offer flexible options that often provide enhanced accessibility. It makes no difference whether the duplex vehicle/trailer parking space is pull-through or pull-in/back-out in design. In either case a duplex parking space with a common access aisle between the spaces is allowable.

E2.3.2 Accessible Recreation Vehicle Parking Spaces

COMMENTARY:

When providing accessible recreational vehicle parking spaces at a boat launching facility, the following considerations should be kept in mind:

1. Recreational vehicle/trailer parking spaces will necessarily need to be up to 65 ft in length and wider than the standard 10-ft width of van-accessible/trailer and vehicle/trailer parking spaces. RV parking spaces consume lots of real estate and have a significant impact on other facility components and operations. Vehicles known as RVs include pickup trucks with camper shells, all the way up to motor homes up to 40 ft in length. At some locations it is common for boaters to pull boats on trailers up to 25 ft long. This is the basis of the “up to 65 ft long” RV/trailer parking space dimensions. These guidelines recommend that RV and RV/trailer parking spaces be 12 ft wide to accommodate the nature and use of such vehicles.

2. Additional facility land area is required to meet the requirements of maneuvering large vehicles into a parking lot, to and from the launching ramp, and into and out of designated “RV” parking spaces. Standard parking lot driveway widths for both one-way and two-way traffic will not provide safe and adequate access for RVs.
3. Typically RV and RV/trailer parking spaces will be located on the backside or outside perimeter of a parking lot to avoid negatively impacting the design and operation of the rest of the parking facilities.
4. Consideration of the above factors will precipitate the making of judgment calls that may not completely meet the requirements and needs of all concerned. For example, RV and RV/trailer parking spaces that are designated “accessible” should be as close as possible to the boat launching ramp, restrooms and any other significant project features that may exist. But to crowd these rather large RV spaces into the areas near the launching ramp and restrooms may very well cause safety and operational problems for all users. These problems could very well include:
 - visibility of pedestrians, including persons with disabilities who are moving about the parking area;
 - children walking or running between parking areas, restrooms, shade armadas, picnic areas, and the launching ramp;
 - visibility of other vehicles entering and departing the facility;
 - obstruction of visibility of the waterbody by persons on shore, facility staff, law enforcement officers, life guards, emergency rescue personnel, and others who may need a continuous clear view of the water, boats being launched and retrieved, and boats being operated on the water.
 - unnecessary concentration of all launching facility activities at or near the head of the launching ramp.

Where needed, the provision of large RV parking spaces around the perimeter or at the backside of the parking area is probably the most reasonable and sensible option. Accessible routes between accessible RV parking spaces can be provided around the parking lot perimeter meeting the requirement that the accessible route not pass behind parked vehicles except the vehicle that a person with a disability arrives in.

Also, a temporary parking area near the launching ramp and restrooms can be provided for dropping off and picking up passengers as required. Such a feature could be of benefit to all persons, not just those with disabilities. In the case of a person with a disability being the driver of the RV, such a person would have to use an accessible route between the designated accessible RV parking spaces and the various facility activity areas. It is sometimes impossible to perfectly meet all the needs and legal requirements when designing, building and operating a recreational

boat launching facility. This is why state and federal accessibility guidelines, rules, titles and regulations speak of reasonable access rather than absolute or universal access.

E2.4.2 Access Aisles for Angled Van-Accessible Parking Spaces

COMMENTARY:

The source of this particular guideline is ADA Standards Section 502.3.4 which states in part, "...angled van parking spaces shall have access aisles located on the passenger side of the parking spaces." The reason for this is the fact that wheelchair lifts are typically located on the passenger side of vehicles. So, the intent is to alleviate the necessity of backing a van into an angled parking space in order to position the passenger-side door adjacent to an access aisle. Additionally, some parking layouts utilize one-way driveways between rows of parking. This eliminates the option to legally drive 'against traffic' in order to back a van into a van-accessible parking space such that the access aisle is on the passenger side of the van.

Not considered in the ADA Standards is the widespread use of pull-through parking spaces at boat launching facilities. If a parking facility is designed such that angled van-accessible parking spaces can be entered and exited from either end, then ADA Standards Section 502.3.4 would be a non-issue. Keep in mind that van-accessible parking spaces are reserved for use by persons with disabilities, but they are not reserved for vans. Any type of vehicle may be parked in a van space provided there is a placard on the windshield or a sticker on the license plate.

E2.4.4 Required Widths of Access Aisles

COMMENTARY:

In ADA Standards Section 502.2, accessible vehicle parking spaces shall be 8 ft wide (96 inch) minimum, and van-accessible parking spaces shall be 11 ft wide (132 inch) minimum. However, the Exception in 502.2 allows van-accessible parking spaces to be 8 ft wide (96 inch) minimum where the adjacent access aisle is 8 ft wide (96 inch) minimum. In either case, the overall width of a van-accessible parking space and the adjacent access aisle would be 16 ft minimum: 11 ft + 5 ft = 16 ft; or 8 ft + 8 ft = 16 ft.

Widening a van-accessible parking space to 11 ft and reducing the access aisle down to 5 ft is very valuable. It addresses the following problems:

1. The access aisle on an individual angled (diagonal parking) van-accessible parking space is required to be located on the passenger side of the parking space. However, if the driver is the person with the disability, the access aisle will be on the wrong side of the vehicle. So the obvious thing to do is to park the vehicle over to the right and perhaps into the access aisle far enough to provide the necessary room to exit and re-enter the vehicle on the driver's side which often includes unloading and re-loading a wheelchair. If the parking space is only 8 ft wide, the situation gets difficult. It is illegal to park in an access aisle, even

with a legal placard or license plate stickers displayed on the parked vehicle, and the parking fine is several hundred dollars! More and more cities and counties now have parking enforcement patrol operations, and these access aisle parking violations are being ticketed. The 11 ft wide minimum van-accessible parking spaces allowed in ADA Standards Section 502.2 addresses this problem by providing an additional 3 ft to the parking space width, allowing the driver some “wiggle room” to park to the left or right side of the van-accessible parking space as needed for driver or passenger accessibility, without encroachment into the access aisle. An 11 ft wide van-accessible parking space offers flexibility, enhanced accessibility, addresses real identified needs of persons using the parking space, and essentially solves this particular access aisle parking violation problem.

2. It is very easy to mistake an 8 ft wide access aisle for an individual parking space. This is especially so at night with little or no parking area lighting, and/or when the pavement is wet and light reflections obliterate the visibility of the access aisle pavement markings. Section 502.2 can essentially eliminate the confusion of 8 ft wide parking spaces adjacent to 8 ft wide access aisles under normal visibility conditions. This will be a high percentage of the time considering the normal boating seasons for inland and coastal waters in California. Problems may still occur under dark and rainy conditions, but 11 ft wide parking spaces and 5 ft wide access aisles along with highly visible signs will reduce the occurrences of inadvertent illegal parking in access aisles.

E2.5.3.3 Signs and Pavement Markings – Accessible Two-Way Pull-Through Spaces **COMMENTARY:**

At some boat launching facility parking lots with pull-through spaces and two-way traffic, two individual vehicles are allowed to enter from opposite directions and occupy an accessible vehicle/trailer parking space. Such cases are a further reason to provide the pavement markings and posted signs at both ends of accessible two-way pull-through vehicle/trailer parking spaces.

E2.5.3.6 Duplex Parking Space Sign Post Clearance **COMMENTARY:**

Assuming accessibility signs are mounted on 2 inch diameter steel posts in a 5 ft wide duplex parking space access aisle, the posts must be located not further than 10 inches from the edges of the access aisle in order to provide a minimum of 36 inches clear between duplex sign posts (10 inches + 2 inches + 36 inches + 2 inches + 10 inches = 60 inches). Therefore, the locating of duplex sign posts in 5 ft wide access aisles must be done carefully and accurately. There is no margin for error in these narrow access aisles. The 36 inch clearance between posts is a minimum clearance, and must be not less than 36 inches. The 10 inch clearance along the edges of the access aisle may be measured from the centerline of the parking space/access aisle paint stripe to the inside edge of the sign posts.

Eight (8) ft wide duplex access aisles are much more forgiving with regard to location of the sign posts. Using the above 10 inch edge inset and 2 inch post diameter will provide 72 inches of clearance between pairs of sign posts. In such cases it is probably prudent to locate the sign posts 15 to 18 inches inside the edges of the access aisles, providing 62 and 56 inch clearances respectively, well above the 36 inch minimum.

Awareness must be maintained with regard to the size of the signs mounted on the posts within access aisles. These signs are required to be not less than 70 square inches in area. Since state and federal access guidelines do not specify any ratio of length and width (7 inches x 10 inches, 5 inches x 14 inches, etc.), common sense must rule. An extreme example lacking common sense would be a sign 1 inch high and 70 inches wide! The signs should be sized such that the outside edge of a posted sign does not encroach into the vertical projection of the actual parking space. This will not prevent impact from vehicles driven by inattentive drivers, but it will certainly help eliminate most of them inside the access aisle. Boat trailers are often pulled behind pickup trucks with camper shells that have tall blocky profiles that can come into contact with signs that encroach into the parking space width.

E3.2.1 Minimum Driveway Widths

COMMENTARY:

Boat launching facility parking lots are primarily utilized by persons operating vehicles with trailers attached. Therefore, parking lot layouts must address the needs for larger turning radii, wider driveways and reasonable maneuvering room. The minimum driveway widths in these GUIDELINES address these needs. However, 24 and 30 ft wide two-way traffic driveways that serve 45 degree, 60 degree and 90 degree parking spaces present a special problem. If sufficient driveway lane width is provided to allow every conceivable vehicle pulling a recreational boat trailer to comfortably make a right-hand turn into a parking space along the right side of the driveway, without swinging to the left and across the centerline to make the right hand turn, the amount of land to provide a parking lot and the budget to do so would increase dramatically. Depending on the size and characteristics of the vehicle/trailer units and the skill levels of the drivers, it may or may not be possible to enter a "right side" vehicle/trailer parking space without swinging to the left to increase the turning radius into a parking space. Therefore, a workable "social compromise" is well recognized among trailer-boat operators who routinely yield to oncoming traffic that needs to make such left-hand swings before entering right-hand vehicle/trailer parking spaces. It is not unlike the recognized necessary practice of large 18-wheeler trucks and buses that have clearly posted signs on the rear of the vehicles that state, "Warning! This vehicle swings wide left to turn right."

E3.2.1 Bullet 2 24 ft Two-Way Driveways Serving 45 degree and 60 degree Parking Spaces

COMMENTARY:

The right-turn parking space entry maneuver is what dictates the 24-ft wide two-way traffic driveway width for two-way driveways at 45 degrees and 60 degrees. Under this layout, only right-hand entrance turns and left-hand exit turns are possible for entering and exiting parking spaces. When making a right-hand turn into a parking space, the maneuvering space is limited to the 12 ft width of the right-hand driveway lane and the 10 ft width of a vehicle/trailer parking space. When exiting, the left turn exit maneuvering space is greatly increased as it includes the width of the left-hand lane that must be crossed to gain access to the right lane in the two-way driveway.

E3.3.1 AC Paving

COMMENTARY:

AC paving works well in a wide variety of climates, is durable if placed over an adequate rock base, and economically affordable for most projects. It does, however, require maintenance from time to time if it cracks or localized settlement creates low spots that sag and become pot holes. The service life of AC paving can be extended by the application of periodic seal coats, crack sealing and overlays.

E3.4.1 Unpaved Parking Lots

COMMENTARY:

Severe climate characteristics can be detrimental to AC paving. Such conditions would include winter snow, freezing temperatures, ice, very poor soil conditions (i.e. peat soils, bogs, leaf mold deposits in forest settings, etc.), and high velocity water flowing over a flooded parking lot built within a river levee system.

Where AC paving cannot be provided, unpaved parking is sometimes utilized in rustic settings at remote locations, but when wet and muddy, may not be usable for parking vehicles and trailers. Bare soil can be covered with compacted gravel, mill slag, decomposed granite and/or volcanic cinders to solve the mud problem. Such surfaces are not durable and will probably require annual repair, regrading and recompacting to restore them back to serviceable condition for the spring, summer and fall boating season. It is not possible to provide durable painted parking space markings on unpaved surfaces, but 4x4 timbers, peeler poles or other locally available natural wood materials can be buried flush in the gravel, slag or cinders, and function as “hard stripes” to delineate individual parking spaces. These wood product items should be secured with lengths of #4 steel rebar driven vertically through 1/2 inch diameter holes drilled on 5 ft centers, or as required. The rebars must be driven flush with the top surface of the wood members to avoid tripping hazards for people and tire damage to vehicles and trailers. Such a securement method is similar to that used in securing concrete and recycled plastic wheel stops at the head of paved parking spaces. The length of the rebars used should be determined on the basis of the local soil conditions and the density of the gravel,

slag or cinder overlay. However, a minimum length of 24 inches is recommended. If a timber or peeler pole is 4 to 6 inches square or round, 18 to 20 inches would extend into the soil for anchorage.

E4.2.3 Cold Water Showers

COMMENTARY:

Shower facilities are intended for use by boaters, water skiers, anglers, swimmers and others involved in boating related activities that may cause them and/or their clothing and gear to come in contact with sea salt, mud, fish cleaning debris, oil, sun screen, and/or foreign matter in or around the water. Such shower facilities are not intended to be on a par with shower facilities in a county or state park, motel or hotel. The provision of warm-water showers, particularly in urban settings, is to invite transients and homeless persons to occupy the restroom buildings as temporary living quarters, usually a violation of local codes. It will increase operation and maintenance costs, including police and fire protection, and effectively diminish the facility's usability and attractiveness to the intended users. A boat launching facility restroom is not the place to address the social and personal needs of transient and homeless persons.

E5.4 Overhead Electrical Powerlines; EXCEPTION: 48 ft Minimum Clearance

COMMENTARY:

The 48 ft minimum clearance for electrical powerlines passing over recreational boat launching facilities and water bodies adjacent to such facilities was arrived at through an extensive review and assessment of overhead clearance standards, codes and requirements of a number of state and federal agencies, and various electrical organizations and entities. The review included data and information from the California Public Utilities Commission (PUC); the California Electrical Code (CEC); the U.S. Corps of Engineers (CoE); the Occupational Safety and Health Administration (OSHA); the National Electrical Safety Code (NESC); the International Association of Electrical Inspectors (IAEI); the Institute of Electrical and Electronic Engineers (IEEE); the National Water Safety Congress (NWSC); the State of Maryland Public Service Commission (PSC); and the Western Australian Department of Consumer and Employment Protection, Division of Energy Safety. Inquiries were specifically made with various state recreational boating agencies.

These efforts were made to obtain a broad and objective input of information, data and advice to assist in the establishment of a safe and reasonable minimum overhead powerline clearance over boat launching facility driveways, parking areas, boat ready/tiedown areas, boat launching ramps, boarding floats and the nearby waters into which boats are launched and retrieved. Some of the entities listed above have minimum overhead clearance requirements that are considerably both higher and lower than the 48 ft minimum overhead clearance eventually arrived at. It was determined that the specific applications and circumstances influenced the final determinations of the various minimum overhead height clearances.

In the determination and application of a 48 ft minimum overhead clearance, consideration was given to the following specific characteristics of trailerable recreational sailboats and recreational boat launching facilities:

1. It is well established that the range of boats that are typically launched and retrieved at boat launching facilities is 14 to 27 ft in length. This is directly related to the maximum length of boats that can safely and legally be towed behind various types of motor vehicles.
2. Sailboats up to 27 ft in length (LOA = length overall) typically are “stepped” with mast heights of about 38 ft, measured (with the sailboat in the water) from the water surface to the extreme top of the mast. This results in a 10 ft clearance under a 48 ft high overhead powerline.
3. Sailboats launched on boat launching ramps are typically transported on small watercraft trailers, not on large commercial semi-trailer rigs. Sailboats rest higher on their trailers than powerboats in order to provide clearance for their keels. Therefore, an in-the-water stepped mast height of 38 ft increases 3 to 5 ft when a 27 ft long sailboat is on a trailer. This results in a maximum vertical height of 41 to 43 ft from the parking lot/driveway pavement, or boat ramp surface, to the top of the mast, 5 ft below the 48 ft minimum overhead clearance. 5 ft is a recognized minimum margin of safety for such applications.
4. Trailered sailboats cannot be transported on roadways and highways with their masts raised because of the innumerable overhead obstructions that would be encountered including powerlines, bridges, underpasses, tunnels, etc. Therefore, the masts must be raised after arriving at a boat launching facility. A typical procedure would be to either raise the mast while parked in a “Boat Ready Area” near the top of the launching ramp, or to raise the mast after the boat is launched and temporarily secured to a boarding float or other available nearby floating dock or pier. Although it is entirely possible for a boater to raise a sailboat mast in some remote area of a parking lot, tow the sailboat to the launching ramp and launch the sailboat, it would not be a normal, typical sailboat launching procedure. But in the interest of public safety, the same 48 ft minimum overhead clearance that applies over the water, boat ramp and boat ready area...also applies over the entire parking lot, driveways, maneuvering areas, and anywhere else a vehicle towing a boat trailer can drive within the defined limits of a recreational boat launching facility.

E6.2.4 Sign Legibility

COMMENTARY:

For example, freeway signs are massive to accommodate larger lettering, numbers and symbols that can quickly be read several hundred feet away by people traveling in fast moving vehicles. In contrast, an information sign located along a walkway to a restroom will be much smaller and can provide more information using smaller lettering sizes as it will only be read by pedestrians who are walking, standing or sitting within a few feet of the sign.

E6.3.2 Sign Size and Design

COMMENTARY:

A 10 ft long x 3 ft high x 8 in thick reinforced concrete sign mounted on a 12 ft long x 24 inch wide x 12 inch high concrete base can have a combined weight of over 5,000 pounds. Such heavy concrete signs are very durable, and cannot easily be stolen as can lighter, smaller wood and metal signs mounted on posts. But heavy concrete signs must be placed at locations where soil conditions will support the heavy weight, and the sign will not slide down an embankment during wet weather, storms, floods or earthquakes. Heavy concrete signs on slopes should be mounted on reinforced concrete footings supported by not less than two 10 inch diameter x 24 inch deep vertical pedestals with rebar cages that will key the entire sign assembly into the bearing soil and/or rock.

Appendix B: 2010 ADA Standards – Recreational Boating Facilities

Background

The Architectural Barriers Act (ABA) was passed by Congress in 1967, and subsequently ABA Guidelines were developed and published.

The Americans with Disabilities Act (ADA) was passed by Congress in 1990 and the following year the Americans with Disabilities Accessibility Guidelines (ADAAG) were approved and published by the Architectural and Transportation Barriers Compliance Board (ATBCB, commonly known as the Access Board). ADAAG provides guidelines for compliance with the ADA in the construction and alteration of facilities in the public and private sectors. Included is general information, instructions, definitions, and accessible criteria for a broad range of facilities including **Recreational Facilities** in ADAAG 15, and **Recreational Boating Facilities** in ADAAG 15.2.

When ADAAG was published in 1991, ADAAG 15 was held in reserve pending research, investigation and development of appropriate criteria upon which to base accessibility guidelines for recreational facilities. In 2002, ADAAG 15 was finally published by the Access Board. However, in July 2004, the Access Board published a new accessibility guideline titled the Americans with Disabilities Act – Architectural Barriers Act Accessibility Guidelines (ADA-ABA), a merged document containing guidelines from both the 1967 ABA guidelines and the 1991 ADA guidelines. For the next six years, approval of this document was pending at the US Department of Justice (USDOJ).

On July 26, 2010 the USDOJ announced approval of the pending document under the new title 2010 ADA Standards for Accessible Design. On September 15, 2010, the new Standards were published in the Federal Register. Six months later on March 15, 2011 the 2010 Standards went into effect and are enforced by the USDOJ.

The requirements for recreational boating facilities are presented in the 2010 Standards in Section 235 and in Chapter 10, Section 1003. These requirements have been reproduced on the following pages of this Appendix B. They are applicable to state and local governments, as well as to public accommodations and commercial facilities. The same standards were applied to federal agencies and on federal property under the authority of the U.S. Department of General Services (DGS) as of May 8, 2006.

Appendix C: 2019 California Building Code

(Code information accurate as of date of publication)

NOTES:

- 2007 CBC Section 1132B.1 Outdoor Occupancies was superseded by 2019 CBC Section 11B-201.1.
- 2007 CBC Section 1132B.2 Parks and Recreational Areas – Boat Docks was superseded by:
 - 2019 CBC Section 11B-235 Recreational Boating Facilities
 - 2019 CBC Section 11B-237 Fishing Piers and Platforms
 - 2019 CBC Section 11B-1003 Recreational Boating Facilities
 - 2019 CBC Section 11B-1005 Fishing Piers and Platforms

CHAPTER 11B ACCESSIBILITY TO PUBLIC BUILDINGS, PUBLIC ACCOMMODATIONS, COMMERCIAL BUILDINGS AND PUBLIC HOUSING

Division 2: Scoping Requirements

11B-201 Application

11B-201.1 Scope

All areas of newly designed and newly constructed buildings and facilities and altered portions of existing buildings and facilities shall comply with these requirements.

11B-235 Recreational Boating Facilities

11B-235.1 General

Recreational boating facilities shall comply with Section 11B-235.

11B-237 Fishing Piers and Platforms

11B-237.1 General

Fishing piers and platforms comply with Section 11B-1005.

Division 10: Recreation Facilities

11B-1003 Recreational Boating Facilities

11B-1003.1 General

Recreational boating facilities shall comply with Section 11B-1003.

11B-1005 Fishing Pier and Platforms

Support for preparation of this document
provided by Moffatt & Nichol



moffatt & nichol

